

For Replacement Parts, call 1-800-543-6400

Pour Pièces de Rechange, appeler 1-800-543-6400

Para Ordenar Repuestos, Sírvase llamer al Concesionario más Cercano a su Domicilio

For parts, products & service information visit
POWER XPERT
 www.campbellhausfeld.com

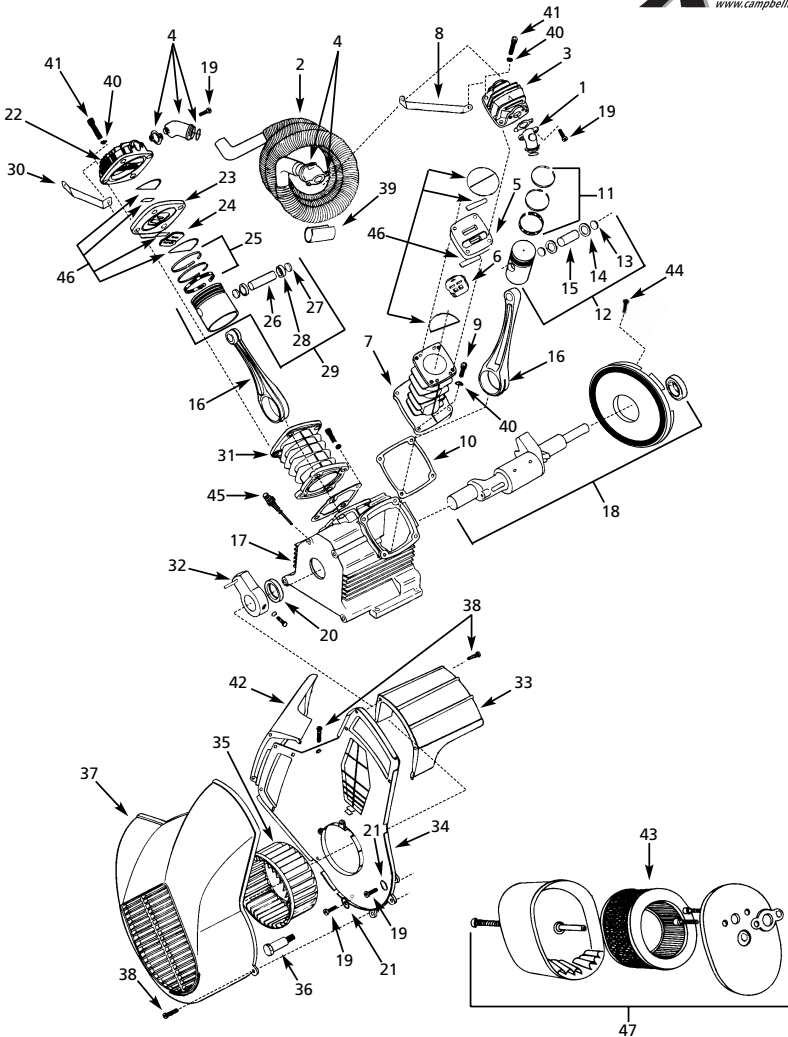

Replacement Parts List

Please provide following information:
 - Model number
 - Serial number (if any)
 - Part description and number as shown in parts list

Address parts correspondence to:
 The Campbell Group
 Attn: Parts Department
 100 Production Drive
 Harrison, OH 45030 U.S.A.

Ref. No.	Description	Part No.	Qty.
1	Discharge tube fitting with gasket	HS902200AJ	1
2	Intercooler	HS009900AV	1
3	High pressure (HP) head	HS000900AV	1
4	Tube fittings with gasket	HS902100AJ	2
5	HP Valve plate	HS001100AV	1
6	HP Plate restrictor	HS003300AV	1
7	HP Cylinder	HS000700AG	1
8	HP Shroud bracket	HS003700AV	1
9	Machine screw 5/16"-18 x 1 1/4"	ST070803AV	8
10	Crankcase gasket	XA009801AV	2
11	HP ring kit	HS901000AJ	1
12	HP Piston and wrist pin assembly	HS000500AJ	1
13	HP Piston pin retainer	HS002901AV	2
14	HP Thrust washer	HS002100AV	2
15	HP Piston pin	HS007100AV	1
16	Connecting rod assembly	HS000400AJ	2
17	Crankcase assembly with bearing (Includes 20 & 45)	HS010000AJ	1
18	Crankshaft/bearing cap with bearing and seal assembly	HS010101AJ	1
19	1/4"-20 x 3/4" Screw	ST120200AV	12
20	30mm Oil seal	ST120000AV	2
21	Washer	ST000600AV	4
22	Low pressure (LP) head	HS001001AV	1
23	LP Valve plate	HS004400AV	1
24	Plate restrictor	HS003200AV	1
25	LP Ring kit	HS901701AJ	1
26	LP Piston pin	HS007200AV	1
27	LP Piston pin retainer	HS002902AV	2
28	LP Thrust washer	HS002000AV	2
29	LP Piston and wrist pin assembly	HS000600AJ	1
30	LP Shroud bracket	HS003600AV	1
31	LP Cylinder	HS000800AG	1
32	Counterweight with screw	HS001900AJ	1
33	Air deflector	BG207400AV	1
34	Shroud back plate	BG207200AV	1
35	Blower wheel	HS001501AV	1
36	3/8"-16 Shoulder bolt	ST120500AV	1
37	Shroud cover	BG207300AV	1
38	5/8" Plascrow	ST058502AV	9
39	1" Hose	ST121600AV	1
40	Lock washer	ST071018AV	16
41	5/16"-18 x 1 1/2" SHCS	ST070819AV	8
42	Filter side air deflector	BG216100AV	1
43	Filter element	ST073903AV	1
44	Screw, 5/16"-18 x 3/4"	ST016000AV	3
45	Dipstick/breather	VT041703AV	1
46	Valve kit 5HP	HS901100AJ	1
47	Air filter assembly (Includes item 43)	ZZ000038AJ	1
★	Gasket kit 5 HP	HS901200AJ	

Limited Warranty

1. **DURATION:** From the date of purchase by the original purchaser as follows: Standard Duty - One Year, Serious Duty - Two Years, Extreme Duty - Three Years.
2. **WHO GIVES THIS WARRANTY (WARRANTOR):**
Campbell Hausfeld / Scott Fetzer Company, 100 Production Drive, Harrison, Ohio, 45030, Telephone: (800) 543-6400
3. **WHO RECEIVES THIS WARRANTY (PURCHASER):** The original purchaser (other than for purposes of resale) of the Campbell Hausfeld compressor.
4. **WHAT PRODUCTS ARE COVERED BY THIS WARRANTY:** Any Campbell Hausfeld air compressor.
5. **WHAT IS COVERED UNDER THIS WARRANTY:** Substantial defects due to material and workmanship with the exceptions noted below.
6. **WHAT IS NOT COVERED UNDER THIS WARRANTY:**
 - A. Implied warranties, including those of merchantability and FITNESS FOR A PARTICULAR PURPOSE ARE LIMITED FROM THE DATE OF ORIGINAL PURCHASE AS STATED IN THE DURATION. If this compressor is used for commercial, industrial or rental purposes, the warranty will apply for ninety (90) days from the date of purchase. Four cylinder single-stage and two-stage compressors are not limited to a ninety (90) day warranty when used in commercial or industrial applications. Some States do not allow limitations on how long an implied warranty lasts, so the above limitations may not apply to you.
 - B. ANY INCIDENTAL, INDIRECT, OR CONSEQUENTIAL LOSS, DAMAGE, OR EXPENSE THAT MAY RESULT FROM ANY DEFECT, FAILURE, OR MALFUNCTION OF THE CAMPBELL HAUSFELD PRODUCT. Some States do not allow the exclusion or limitations of incidental or consequential damages, so the above limitation or exclusion may not apply to you.
 - C. Any failure that results from an accident, purchaser's abuse, neglect or failure to operate products in accordance with instructions provided in the owner's manual(s) supplied with compressor.
 - D. Pre-delivery service, i.e. assembly, oil or lubricants, and adjustment.
 - E. Items or service that are normally required to maintain the product, i.e. lubricants, filters and gaskets, etc.
 - F. Gasoline engines and components are expressly excluded from coverage under this limited warranty. The Purchaser must comply with the warranty given by the engine manufacturer which is supplied with the product.
 - G. Additional items not covered under this warranty:
 1. All Compressors
 - a. Any component damaged in shipment or any failure caused by installing or operating unit under conditions not in accordance with installation and operation guidelines or damaged by contact with tools or surroundings.
 - b. Pump or valve failure caused by rain, excessive humidity, corrosive environments or other contaminants.
 - c. Cosmetic defects that do not interfere with compressor functionality.
 - d. Rusted tanks, including but not limited to rust due to improper drainage or corrosive environments.
 - e. Electric motors, check valves and pressure switches after the first year of ownership.
 - f. Drain cocks.
 - g. Damage due to incorrect voltage or improper wiring.
 - h. Other items not listed but considered general wear parts.
 - i. Pressure switches, air governors and safety valves modified from factory settings.
 2. Lubricated Compressors
 - a. Pump wear or valve damage caused by using oil not specified.
 - b. Pump wear or valve damage caused by any oil contamination or by failure to follow proper oil maintenance guidelines.
 3. Belt Drive / Direct Drive / Gas Driven Compressors
 - a. Belts.
 - b. Ring wear or valve damage from inadequate filter maintenance.
 - c. Manually adjusted load/unload and throttle control devices.
7. **RESPONSIBILITIES OF WARRANTOR UNDER THIS WARRANTY:** Repair or replace, at Warrantor's option, compressor or component which is defective, has malfunctioned and/or failed to conform within duration of the warranty period.
8. **RESPONSIBILITIES OF PURCHASER UNDER THIS WARRANTY:**
 - A. Provide dated proof of purchase and maintenance records.
 - B. Portable compressors or components must be delivered or shipped to the nearest Campbell Hausfeld Authorized Service Center. Freight costs, if any, must be borne by the purchaser.
 - C. Use reasonable care in the operation and maintenance of the products as described in the owner's manual(s).
9. **WHEN WARRANTOR WILL PERFORM REPAIR OR REPLACEMENT UNDER THIS WARRANTY:**
 - A. Repair or replacement will be scheduled and serviced according to the normal work flow at the servicing location, and depending on the availability of replacement parts.
 - B. If the purchaser does not receive satisfactory results from the Authorized Service Center, the purchaser should contact Campbell Hausfeld (see paragraph 2).

Limited Warranty applies in the U.S. and Canada only and gives you specific legal rights. You may also have other rights which vary from State to State or country to country.