

PARTS MANUAL

Models

**EX13, EX17, EX21
ENGINE**

PUB-EP1676
Rev. 07/03

Robin America, Inc.

940 Lively Blvd. • Wood Dale, IL 60191 • Phone: 630-350-8200 • Fax: 630-350-8212
e-mail: sales@robinamerica.com • www.robinamerica.com

© Copyright 2003 Robin America, Inc.

HOW TO USE THIS MANUAL

Robin engines are identified by MODEL, SPECIFICATION, and CODE NUMBER. For each model there may be many different versions called specifications. Each specification will be unique in some way. The difference may only be the paint color or it may have a different type of PTO or some other significant difference.

In order to identify the correct service part number, it is important to confirm the specification and code numbers for your engine. The specification and code number together are known as the PRODUCT NUMBER.

All Robin 4 cycle engines have a Product Number label similar to the label illustrated below.

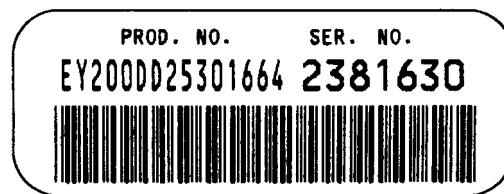
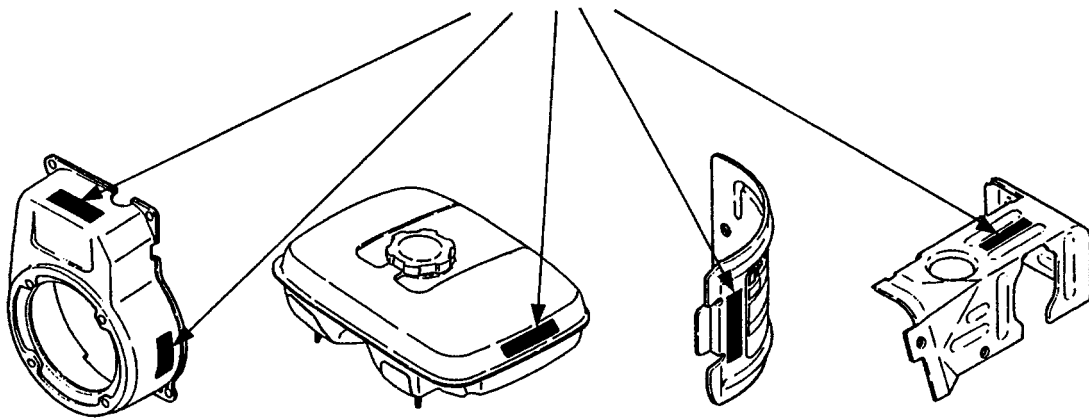

The Product Number Label has a 15 digit alphanumeric string that consists of the SPECIFICATION (SPEC) number (11 digits) and the CODE number (4 digits). Please note the illustration below:

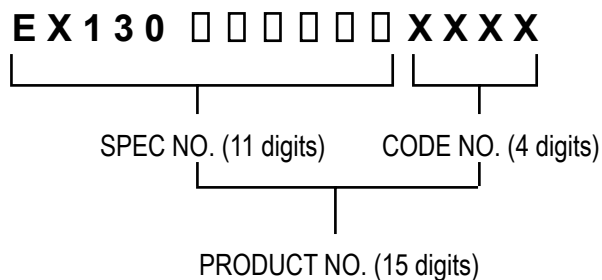

MANUAL LAYOUT

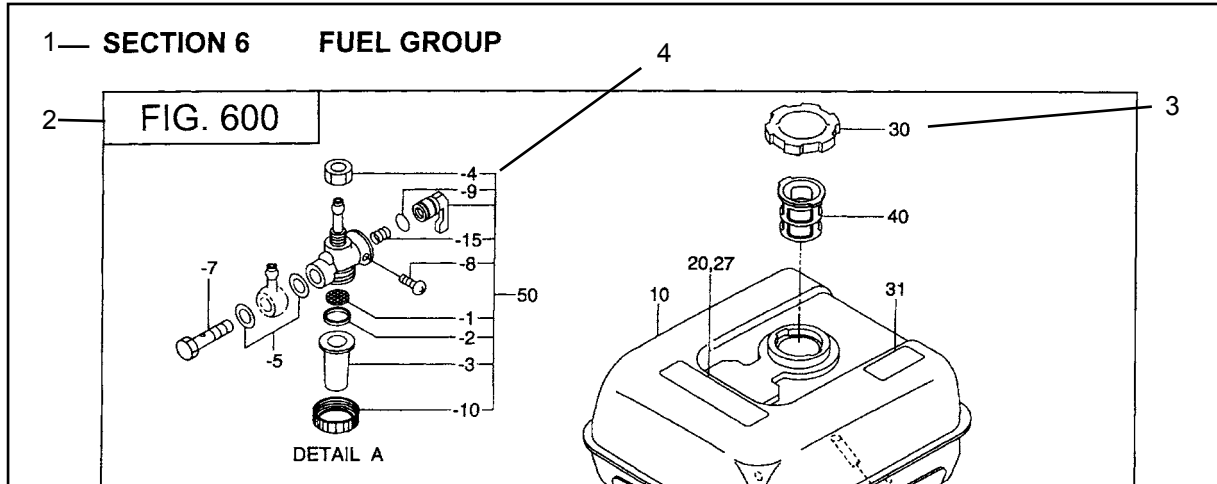

REF.	PART NO.	DESCRIPTION	QTY.	REMARKS	FROM-TO	FIG.
10	267-60103-01	FUEL TANK CP	1	YD, YS TYPE, BLACK		600
	267-60101-01	FUEL TANK CP	1	YELLOW		600
27	073-20039-00	LABEL, WARNING	1	YD, YS TYPE		600
30	043-04300-15	FUEL TANK CAP CP	1			600
31	267-95201-03	LABEL, EMISSION	1	YD, YS TYPE		600
40	064-13600-10	FUEL FILTER	1			600
50	064-20021-01	FUEL STRAINER AY	1			600
-1	064-20002-20	FILTER	1			600
-2	064-20002-30	GASKET	1			600
-3	064-20019-10	CUP	1			600

1. SECTION NAME Parts are broadly classified according to their functions. Refer to the Group Index (table of contents) for respective section name.
2. FIG. No. The FIG. number indexes the reference and part numbers to the illustration. Figure numbers that vary only in the tens place (i.e.: 700 and 710) are in a group of the same section (i.e.:Electrical Device Group).
3. REF. No. The Reference number identifies the part illustration with the corresponding part number in the part list.
4. SUBASSEMBLY SUBASSEMBLY parts of part assembly are listed below the assembly part. The subassembly part reference number is indicated by the number led by "-" such as "-1", "-2".
5. PART NUMBER It is the number assigned for sales unit. Use the PART No. when making an order.
6. DESCRIPTION It is designation of the part.
7. QTY. Quantity of each part used for each product.
8. REMARKS This gives a distinctive feature and/or a supplementary comment for the type, the specification, and the part concerned. It also shows part number(s) interchangeable for the part.
9. FROM-TO This section shows the CODE No. to indicate the history of progress in which improved parts have been introduced in the product. The FROM-TO CODE No. helps to identify PART No. being employed in the product concerned. See the examples below:
 - The part is used in the product irrespective of CODE No.
 - 2101- The part is used in the products with CODE No. of 2101 and after this number.
 - 2100 The part is used in the products with CODE No. of 2100 and before this number.

GROUP INDEX

Group Name	Page
CRANKCASE GROUP	6
CRANKSHAFT GROUP	8
INTAKE and EXHAUST GROUP	10
GOVERNOR GROUP	18
COOLING and STARTING GROUP	22
FUEL, LUBRICANT GROUP	26
CARBURETOR GROUP	28
ELECTRIC DEVICE GROUP	32
ACCESSORY GROUP	36

INDEX OF DESCRIPTION SYMBOLS			
SYMBOL	DESCRIPTION	SYMBOL	DESCRIPTION
AY	ASSEMBLY	P=	PITCH (in mm)
CP	COMPLETE	P.T.O. (PTO)	POWER TAKE OFF
EX	EXPORT (from Japan)	REF	REFERENCE
FIG	FIGURE	R.H. (RH)	RIGHT HAND SIDE
FR	FRONT	RR	REAR
"	INCH	STD.	STANDARD
INCL.	INCLUDE	SW	SWITCH
~L	LITER	T=	THICKNESS (in mm)
L=	LENGTH (in. mm)	UN	UNIT
L.H. (LH)	LEFT-HAND SIDE	U.S.	UNDER SIZE
MECH	MECHANICAL	~V	VOLTAGE
NO (NON)	NONE	~W	WATT
OPT	OPTIONAL	W/	WITH
O.S.	OVER SIZE	W/O	WITHOUT

SECTION 1 CRANKCASE GROUP

FIG. 100

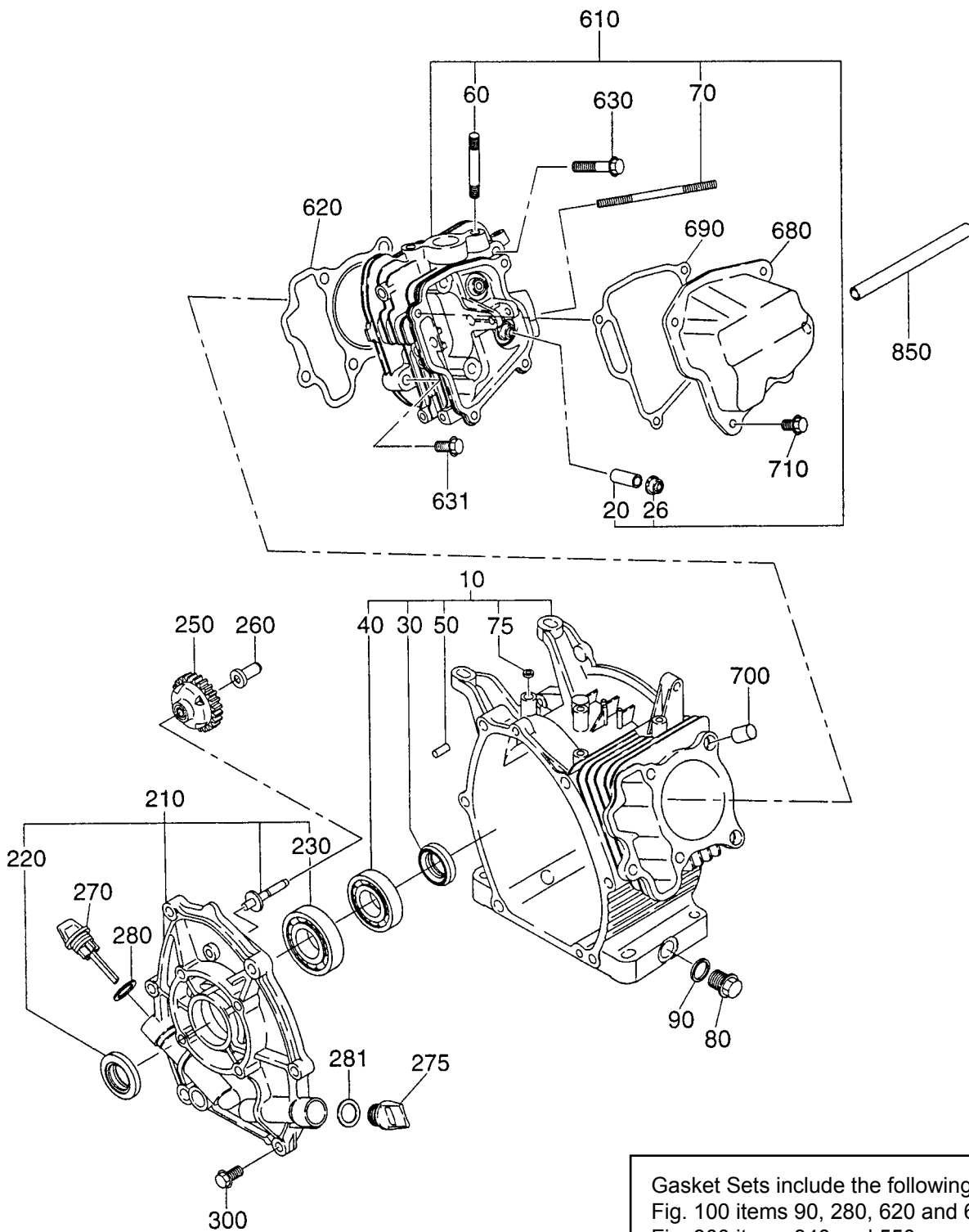

Gasket Sets include the following:
 Fig. 100 items 90, 280, 620 and 690
 Fig. 300 items 340 and 550

SECTION 1 CRANKCASE GROUP

REF.	PART NO.	DESCRIPTION	QTY.	REMARKS	FROM-TO	FIG.
10	276-10102-41	CRANKCASE CP	1	EX13, w/ oil sensor		100
	276-10101-41	CRANKCASE CP	1	EX13, w/o oil sensor		100
10	277-10102-41	CRANKCASE CP	1	EX17, w/ oil sensor		100
	277-10101-41	CRANKCASE CP	1	EX17, w/o oil sensor		100
10	278-10102-41	CRANKCASE CP	1	EX21, w/ oil sensor		100
	278-10101-41	CRANKCASE CP	1	EX21, w/o oil sensor		100
20	237-14201-03	VALVE GUIDE	2			100
26	277-16010-01	STEM SEAL	1			100
30	044-02502-00	OIL SEAL	1			100
40	060-02800-21	BALL BEARING	1			100
50	277-15011-03	PIPE KNOCK	2			100
60	010-50802-50	STUD	2			100
70	010-50603-51	STUD	2			100
75	044-00600-20	OIL SEAL	1			100
80	040-11400-30	PLUG	2			100
90	021-11400-20	GASKET	2			100
210	277-11002-21	MAIN BEARING COVER CP	1	SAE		100
	277-11001-31	MAIN BEARING COVER CP	1	Metric		100
220	044-02502-10	OIL SEAL	1			100
230	060-02501-40	BALL BEARING	1			100
250	277-45004-H1	GOVERNOR GEAR CP	1			100
260	277-41901-03	GOVERNOR SLEEVE	1			100
270	277-63601-13	OIL GAUGE	1			100
275	277-65001-03	FILLER PLUG	1			100
280	021-31600-20	GASKET	1			100
281	021-31600-20	GASKET	1			100
300	001-04083-50	FLANGE BOLT	6			100
610	276-13001-01	CYLINDER HEAD CP	1	EX13, Old style	~ 2099999	100
	276-13001-11	CYLINDER HEAD CP	1	EX13, New style	2100000~	100
	277-13001-01	CYLINDER HEAD CP	1	EX17, Old style	~ 2099999	100
	277-13001-11	CYLINDER HEAD CP	1	EX17, New style	2100000~	100
	278-13001-01	CYLINDER HEAD CP	1	EX21, Old style	~ 2099999	100
	278-13001-11	CYLINDER HEAD CP	1	EX21, New style	2100000~	100
620	276-15001-13	GASKET, head	1	EX13		100
	277-15001-23	GASKET, head	1	EX17 and EX21		100
630	011-00802-40	FLANGE BOLT	4			100
631	001-04083-50	FLANGE BOLT	1			100
680	277-15501-01	ROCKER COVER CP	1			100
690	277-16001-03	GASKET, rocker cover	1			100
700	277-15011-03	PIPE KNOCK	2			100
710	011-00600-20	FLANGE BOLT	4			100
850	085-10800-00	RUBBER PIPE	1			100
960	276-99001-07	GASKET SET	1	EX13		100
	277-99001-07	GASKET SET	1	EX17 and EX21		100
	EX0-20000-01	GASKET IN A TUBE				

SECTION 2 CRANKSHAFT GROUP

FIG. 200

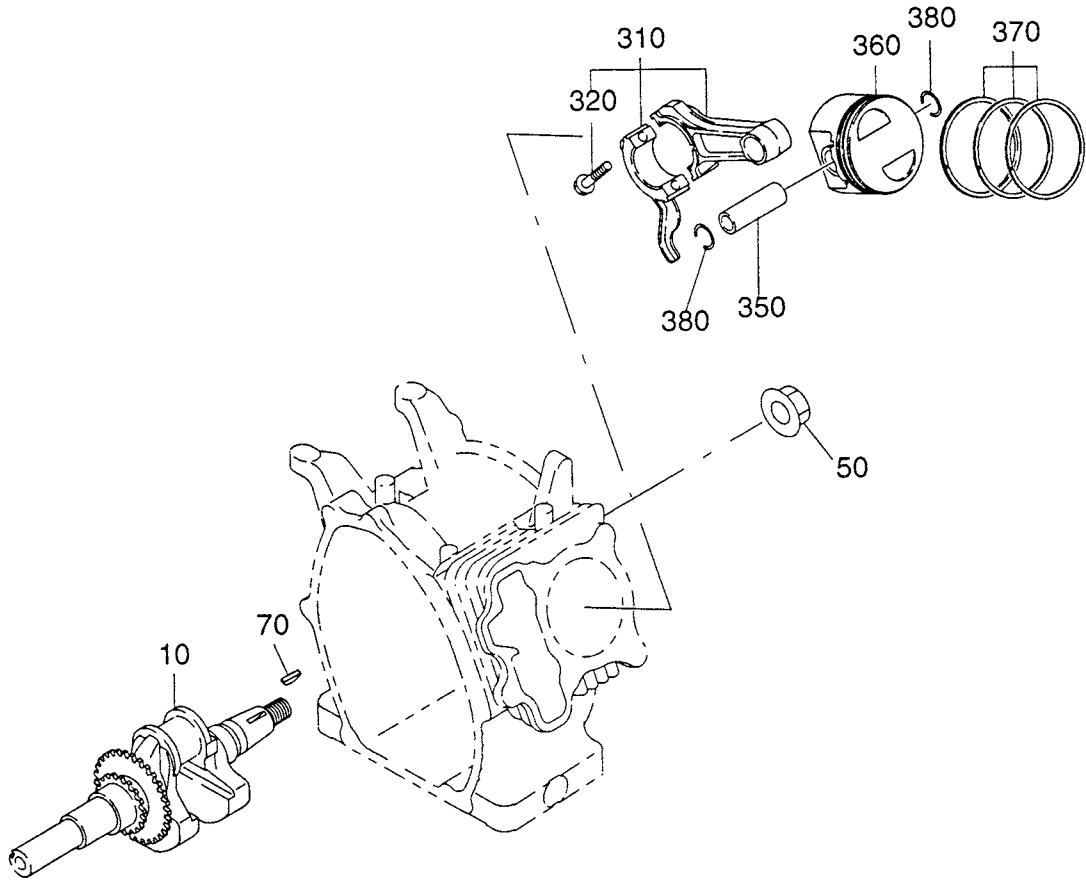

SECTION 2 CRANKSHAFT GROUP

REF.	PART NO.	DESCRIPTION	QTY.	REMARKS	FROM-TO	FIG.
10	276-20901-21	CRANKSHAFT CP	1	3/4" key, 5/16 tap - EX13		200
	276-21001-21	CRANKSHAFT CP	1	5/8" Pump - EX13		200
	276-21201-21	CRANKSHAFT CP	1	SAE Taper - EX13		200
	276-20201-31	CRANKSHAFT CP	1	Metric 18mm - EX13		200
	276-20301-21	CRANKSHAFT CP	1	Metric pump 18mm - EX13		200
	276-20701-21	CRANKSHAFT CP	2	Metric Taper - EX13		200
10	277-20901-21	CRANKSHAFT CP	1	3/4" key, 5/16 tap - EX17		200
	277-21001-21	CRANKSHAFT CP	1	5/8" Pump - EX17		200
	277-21201-21	CRANKSHAFT CP	1	SAE Taper - EX17		200
	277-20201-21	CRANKSHAFT CP	1	Metric 20mm - EX17		200
	277-20301-21	CRANKSHAFT CP	1	Metric Pump 20mm - EX17		200
	277-20701-21	CRANKSHAFT CP	1	Metric Taper - EX17		200
10	278-20901-31	CRANKSHAFT CP	1	3/4" key, 5/16 tap - EX21		200
	278-21001-31	CRANKSHAFT CP	1	5/8" Pump - EX21		200
	278-21201-31	CRANKSHAFT CP	1	SAE Taper - EX21		200
	278-20201-31	CRANKSHAFT CP	1	Metric 20mm - EX21		200
	278-20301-21	CRANKSHAFT CP	1	Metric Pump 20mm - EX21		200
	278-20701-21	CRANKSHAFT CP	1	Metric Taper - EX21		200
50	018-01400-20	FLANGE NUT	1			200
70	032-30300-10	WOODRUFF KEY	1			200
310	276-22501-10	CONNECTING ROD AY	1	EX13		200
	277-22501-10	CONNECTING ROD AY	1	EX17		200
	278-22501-10	CONNECTING ROD AY	1	EX21		200
320	277-23001-03	CONNECTING ROD BOLT	2			200
350	276-23301-03	PISTON PIN	1	EX13		200
	277-23301-03	PISTON PIN	1	EX17 and EX21		200
360	276-23401-03	PISTON	1	EX13 - STD		200
	276-23403-03	PISTON	1	EX13 - Oversize 0.25mm		200
	276-23404-03	PISTON	1	EX13 - Oversize 0.55mm		200
	277-23401-03	PISTON	1	EX17 and EX21 - STD		200
	277-23403-03	PISTON	1	EX17 and 21 Oversize 0.25mm		200
	277-23404-03	PISTON	1	EX17 and EX21 Oversize 0.50mm		200
370	276-23511-17	PISTON RING SET	1	EX13 - STD		200
	276-23512-17	PISTON RING SET	1	EX13 - Oversize 0.25mm		200
	276-23513-17	PISTON RING SET	1	EX13 - Oversize 0.50mm		200
	277-23511-17	PISTON RING SET	1	EX17 and EX21 - STD		200
	277-23512-17	PISTON RING SET	1	EX17 and EX21 Oversize 0.25mm		200
	277-23513-17	PISTON RING SET	1	EX17 and EX21 Oversize 0.50mm		200
380	215-25004-03	CLIP	2	EX13		200
	056-51600-10	CLIP	2	EX17 and EX21		200

SECTION 3 INTAKE and EXHAUST GROUP - NEW STYLE

FIG. 300

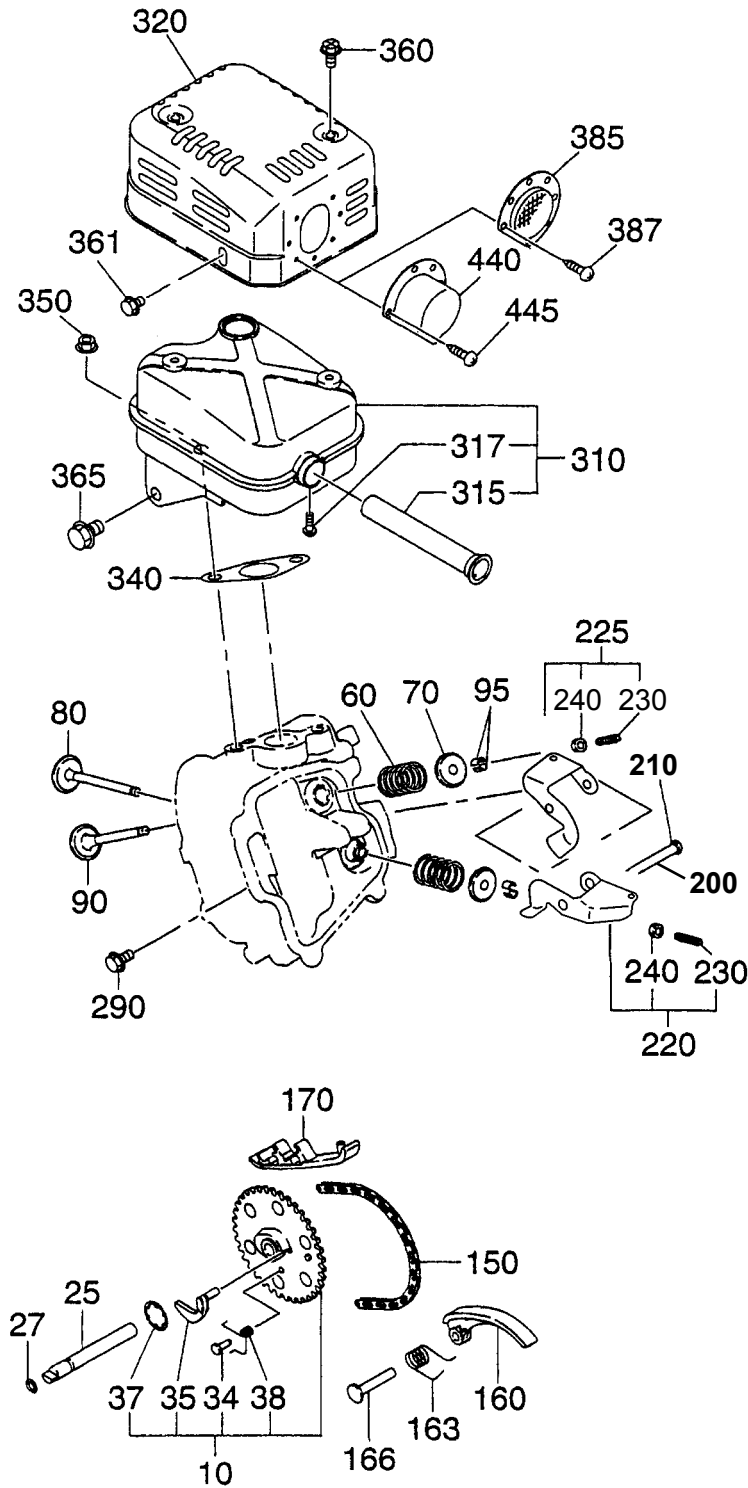

SECTION 3 INTAKE and EXHAUST GROUP - NEW STYLE

REF.	PART NO.	DESCRIPTION	QTY.	REMARKS	FROM-TO	FIG.
10	277-31601-11	CAMSHAFT CP	1		2100000~	300
25	277-35101-03	PIN, camshaft	1		2100000~	300
27	024-00600-10	O RING	1		2100000~	300
34	277-38601-03	PIN, spring	1		2100000~	300
35	277-36401-03	RELEASE LEVER	1		2100000~	300
37	277-36501-03	CLIP	1		2100000~	300
38	277-38702-03	RETURN SPRING	1		2100000~	300
60	279-33601-03	VALVE SPRING	2		2100000~	300
70	269-33701-03	RETAINER VALVE SPRING	2		2100000~	300
80	276-33401-33	INTAKE VALVE	1	EX13	2100000~	300
	277-33401-13	INTAKE VALVE	1	EX17 and EX21	2100000~	300
90	276-33501-33	EXHAUST VALVE	1	EX13	2100000~	300
	277-33501-13	EXHAUST VALVE	1	EX17 and EX21	2100000~	300
95	132-10KA0-31	COLLET VALVE	4		2100000~	300
150	276-35601-11	TIMING CHAIN CP	1	EX13	2100000~	300
	277-35601-11	TIMING CHAIN CP	1	EX17	2100000~	300
	278-35601-11	TIMING CHAIN CP	1	EX21	2100000~	300
160	277-36911-03	TENTIONER	1		2100000~	300
163	277-37101-03	SPRING, tentioner	1		2100000~	300
166	277-36902-03	PIN, tentioner	1		2100000~	300
170	277-36913-13	CHAIN GUIDE	1		2100000~	300
200	277-35002-03	PIN, rocker	1		2100000~	300
210	003-13050-00	CLIP	1		2100000~	300
220	277-36201-00	ROCKER ARM AY, in	1		2100000~	300
225	277-36202-00	ROCKER ARM AY, ex	1		2100000~	300
230	014-90500-20	ADJUST SCREW	2		2100000~	300
240	017-00500-30	NUT	2		2100000~	300
290	011-00600-20	FLANGE BOLT	1		2100000~	300
310	276-30101-11	MUFFLER CP	1	EX13	2100000~	300
	277-30101-11	MUFFLER CP	1	EX17	2100000~	300
	278-30101-11	MUFFLER CP	1	EX21	2100000~	300
310	276-30111-01	MUFFLER CP	1	EX13, w/ spark arrestor	2100000~	300
	277-30111-01	MUFFLER CP	1	EX17,21, w/ spark arrestor	2100000~	300
315	277-37601-01	SPARK ARRESTOR	1		2100000~	300
317	015-00400-60	TAPPING SCREW	1		2100000~	300
320	277-34201-11	MUFFLER COVER	1		2100000~	300
340	277-35201-13	GASKET, muffler	1		2100000~	300
350	980-20082-80	FLANGE NUT	2		2100000~	300
360	015-20600-90	TAPPING BOLT	2		2100000~	300
361	011-00600-10	FLANGE BOLT	1		2100000~	300
365	011-00801-50	FLANGE BOLT	1		2100000~	300
385	277-37203-01	SCREEN CP	1		2100000~	300
387	015-00400-60	TAPPING SCREW	2		2100000~	300
440	277-37001-01	DEFLECTOR CP	1		2100000~	300
445	015-00400-60	TAPPING SCREW	2		2100000~	300

FIG. 300

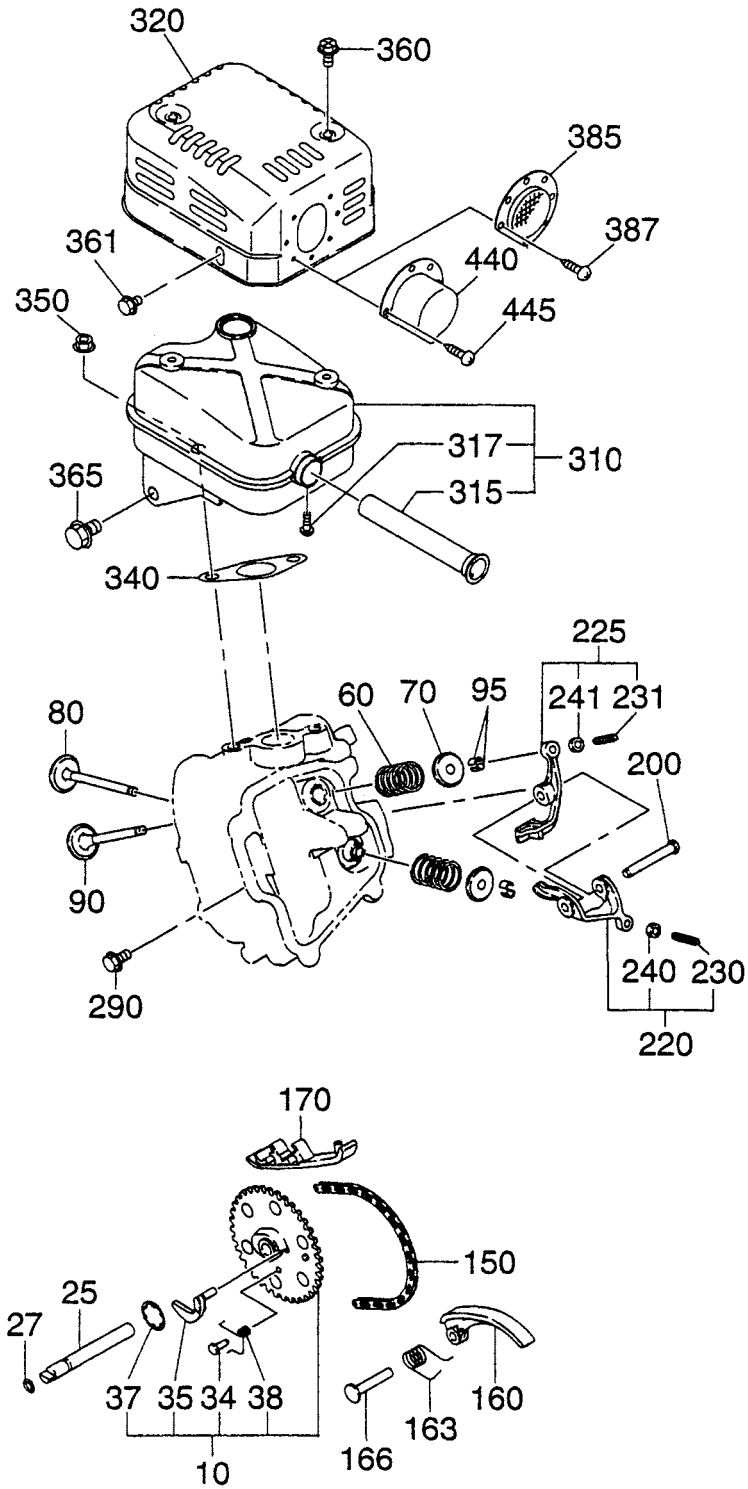

SECTION 3 INTAKE and EXHAUST GROUP - OLD STYLE

REF.	PART NO.	DESCRIPTION	QTY.	REMARKS	FROM-TO	FIG.
10	277-31601-01	CAMSHAFT CP	1		~2099999	300
25	277-35101-03	PIN, camshaft	1		~2099999	300
27	024-00600-10	O RING	1		~2099999	300
34	277-38601-03	PIN, spring	1		~2099999	300
35	277-36401-03	RELEASE LEVER	1		~2099999	300
37	277-36501-03	CLIP	1		~2099999	300
38	277-38701-03	RETURN SPRING	1		~2099999	300
60	279-33601-03	VALVE SPRING	2		~2099999	300
70	269-33701-03	RETAINER VALVE SPRING	2		~2099999	300
80	276-33401-33	INTAKE VALVE	1	EX13	~2099999	300
	277-33401-13	INTAKE VALVE	1	EX17 and EX21	~2099999	300
90	276-33501-33	EXHAUST VALVE	1	EX13	~2099999	300
	277-33501-13	EXHAUST VALVE	1	EX17 and EX21	~2099999	300
95	132-10KA0-31	COLLET VALVE	4		~2099999	300
150	276-35601-01	TIMING CHAIN CP	1	EX13	~2099999	300
	277-35601-01	TIMING CHAIN CP	1	EX17	~2099999	300
	278-35601-01	TIMING CHAIN CP	1	EX21	~2099999	300
160	277-36911-03	TENTIONER	1		~2099999	300
163	277-37101-03	SPRING, tentioner	1		~2099999	300
166	277-36902-03	PIN, tentioner	1		~2099999	300
170	277-36913-13	CHAIN GUIDE	1		~2099999	300
200	277-35001-23	PIN, rocker	1		~2099999	300
220	277-36101-00	ROCKER ARM AY, in	1		~2099999	300
225	277-36102-00	ROCKER ARM AY, ex	1		~2099999	300
230	014-90500-10	ADJUST SCREW	1		~2099999	300
231	014-90500-10	ADJUST SCREW	1		~2099999	300
240	017-00500-20	NUT	1		~2099999	300
241	017-00500-20	NUT	1		~2099999	300
290	011-00600-20	FLANGE BOLT	1		~2099999	300
310	276-30101-11	MUFFLER CP	1	EX13	~2099999	300
	277-30101-11	MUFFLER CP	1	EX17	~2099999	300
	278-30101-11	MUFFLER CP	1	EX21	~2099999	300
	276-30111-01	MUFFLER CP	1	EX13 - w/spark arrestor	~2099999	300
	277-30111-01	MUFFLER CP	1	EX17,EX21 - w/ spark arrestor	~2099999	300
315	277-37601-01	SPARK ARRESTOR	1		~2099999	300
317	015-00400-60	TAPPING SCREW	1		~2099999	300
320	277-34201-01	MUFFLER COVER	1		~2099999	300
340	277-35201-03	GASKET, muffler	1		~2099999	300
350	980-20082-80	FLANGE NUT	2		~2099999	300
360	015-20600-90	TAPPING BOLT	2		~2099999	300
361	011-00600-10	FLANGE BOLT	1		~2099999	300
365	011-00801-50	FLANGE BOLT	1		~2099999	300
440	277-37001-03	DEFLECTOR	1		~2099999	300
445	015-00400-60	TAPPING SCREW	2		~2099999	300

SECTION 3 INTAKE and EXHAUST GROUP

FIG. 310

(A)

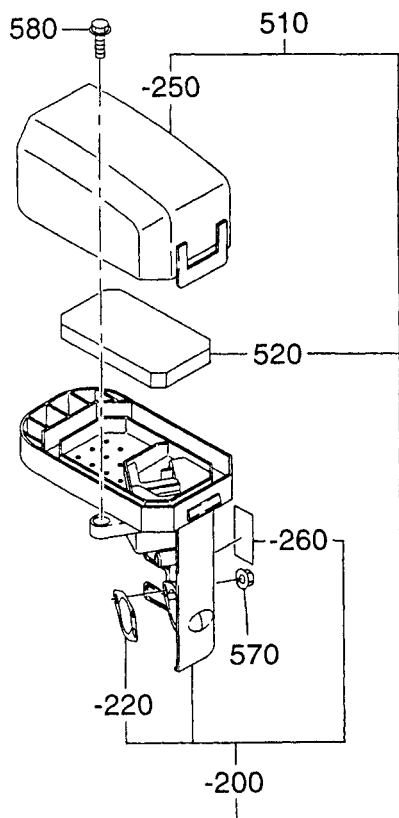

(B)

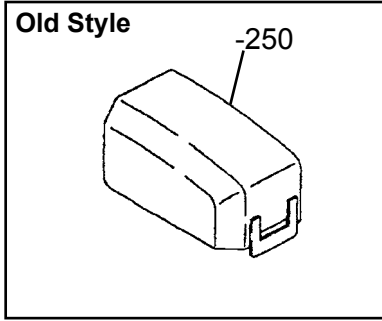
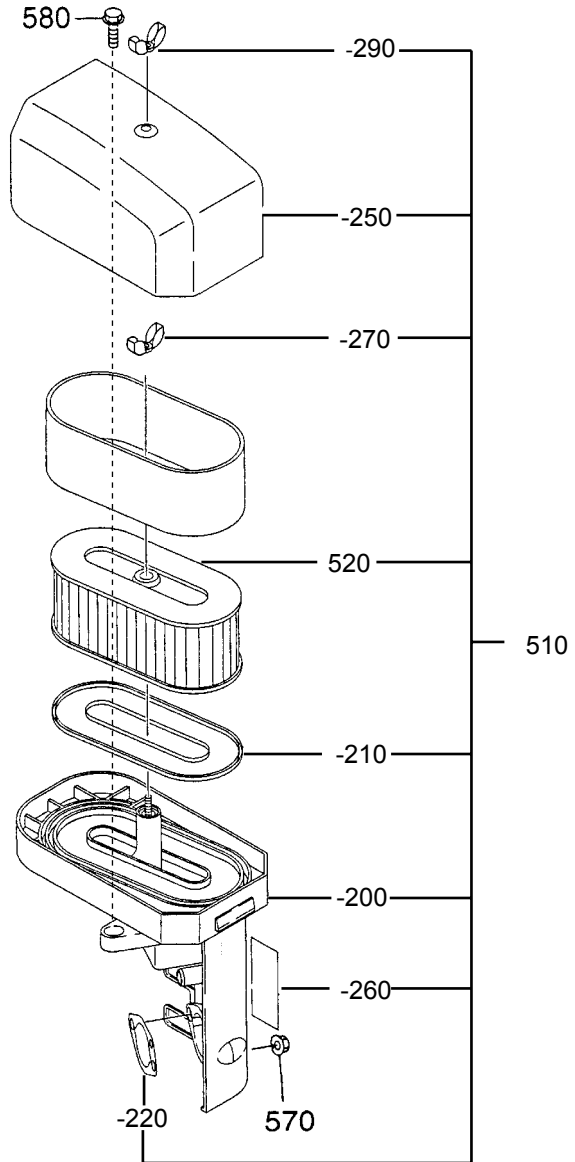

SECTION 3 INTAKE and EXHAUST GROUP

REF.	PART NO.	DESCRIPTION	QTY.	REMARKS	FROM-TO	FIG.
510	277-32611-00	AIR CLEANER AY	1	Foam		310A
	277-32615-00	AIR CLEANER AY	1	Dual element, new style	2100000~	310B
	277-32612-00	AIR CLEANER AY	1	Dual element, old style	~2099999	inset
-200	277-32601-08	BASE CP	1	Foam		310A
-200	277-32630-08	BASE CP	1	Dual element, new style		310B
-200	277-32605-08	BASE CP	1	Dual element, old style		310B
-210	277-32610-08	PACKING	1	Dual element, old style		310B
-220	277-32604-08	GASKET	1			310
-250	277-32602-08	COVER CP	1	Foam		310A
-250	277-32640-08	COVER CP	1	Dual element, new style		310B
*-250	277-32602-08	COVER CP	1	Dual element, old style		inset
-260	277-32609-08	LABEL	1			310
-270	277-32741-08	WING NUT	1	Dual element, new style		310B
-270	277-32607-08	WING NUT	1	Dual element, old style		310B
-290	277-32740-08	WING NUT	1	Dual element		310B
520	277-32603-08	ELEMENT	1	Foam		310A
	277-32611-07	ELEMENT	1	Dual element		310B
570	002-38060-00	FLANGE NUT	2			310
580	011-00600-50	FLANGE BOLT	1			310

SECTION 3 INTAKE and EXHAUST GROUP

FIG. 320

Cyclone Pre-Cleaner

(C)

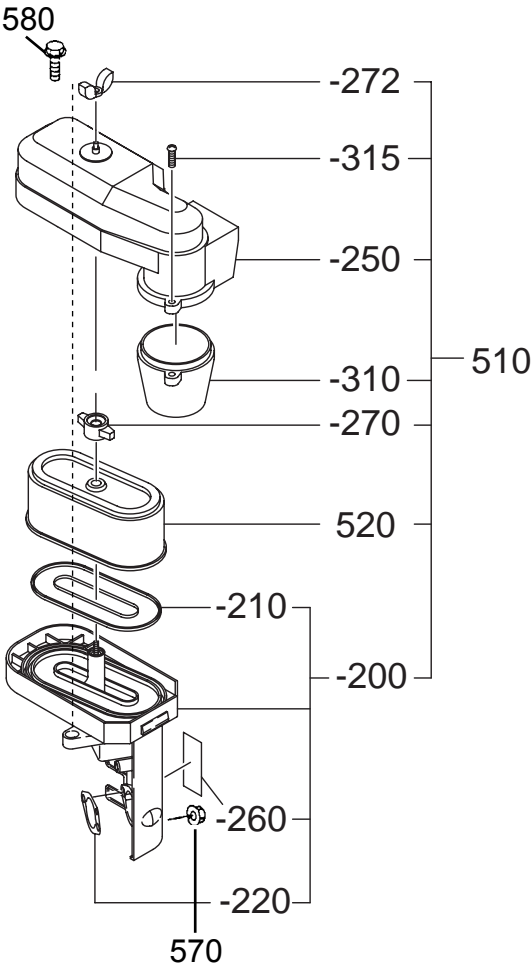

(D)

Low Profile

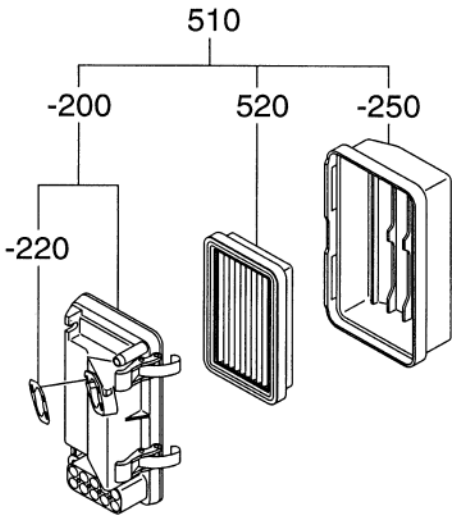

SECTION 4 GOVERNOR GROUP - New Style

FIG. 400

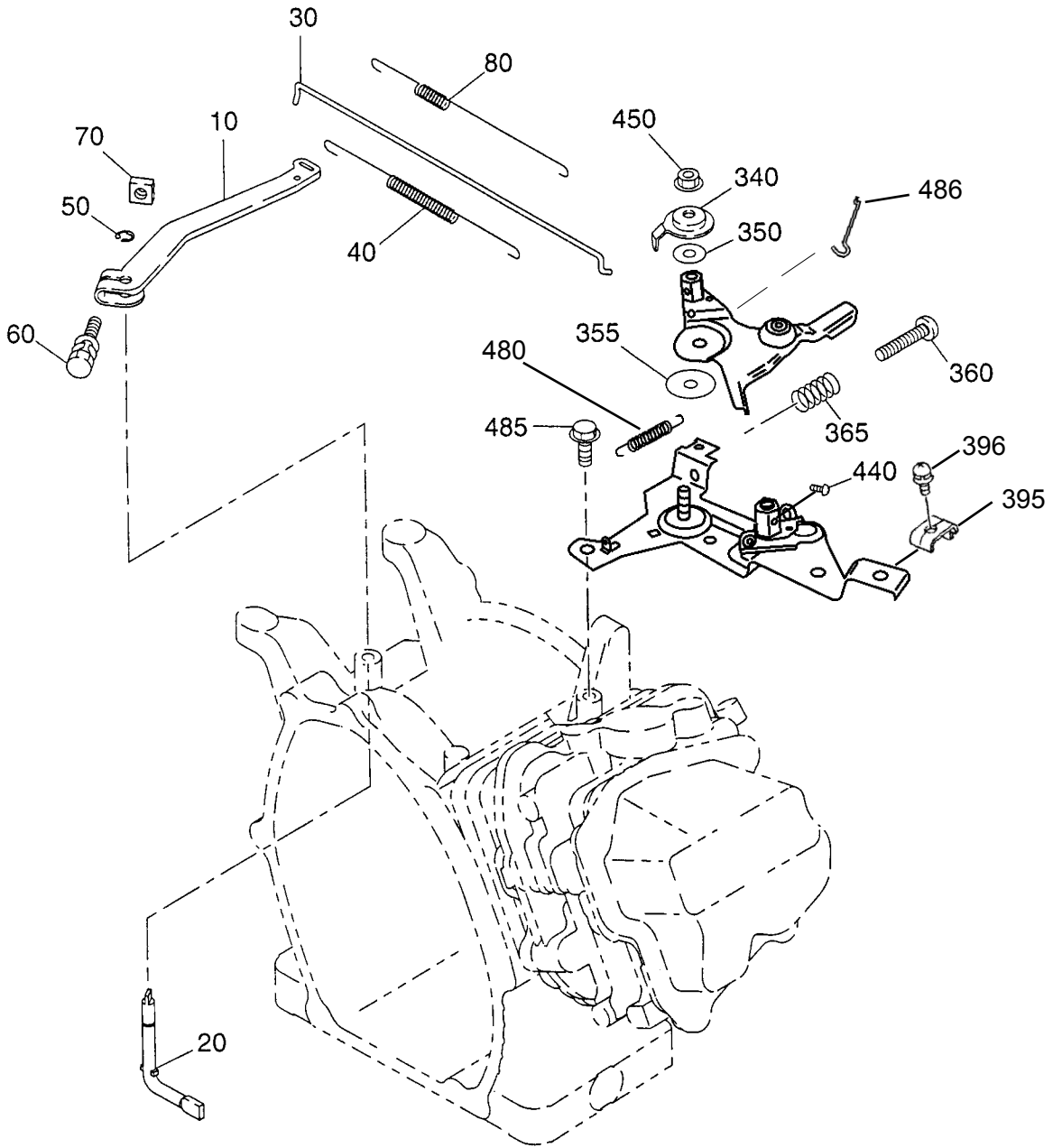

SECTION 4 GOVERNOR GROUP - Old Style

FIG. 400

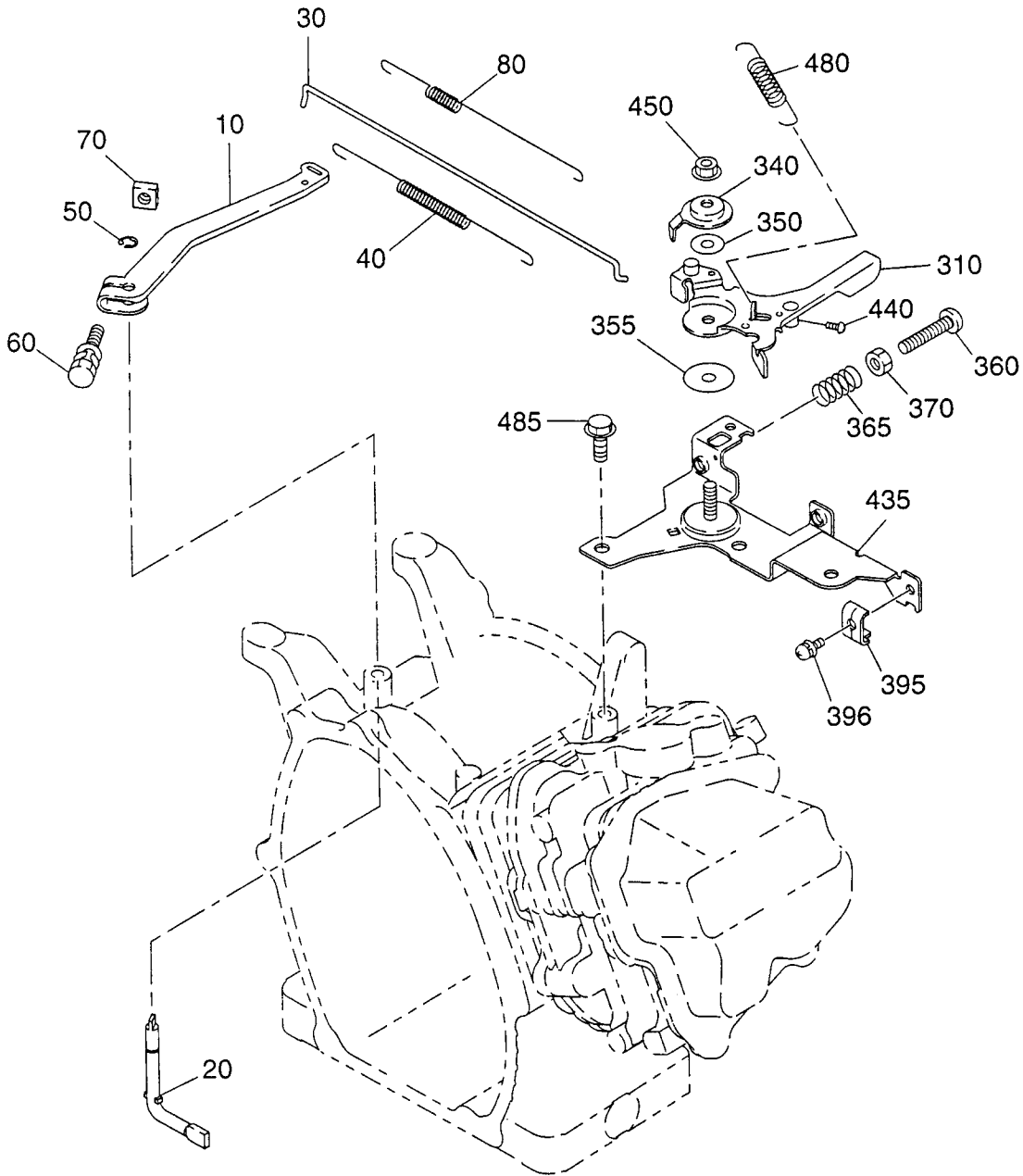

SECTION 5 COOLING and STARTING GROUP

FIG. 500

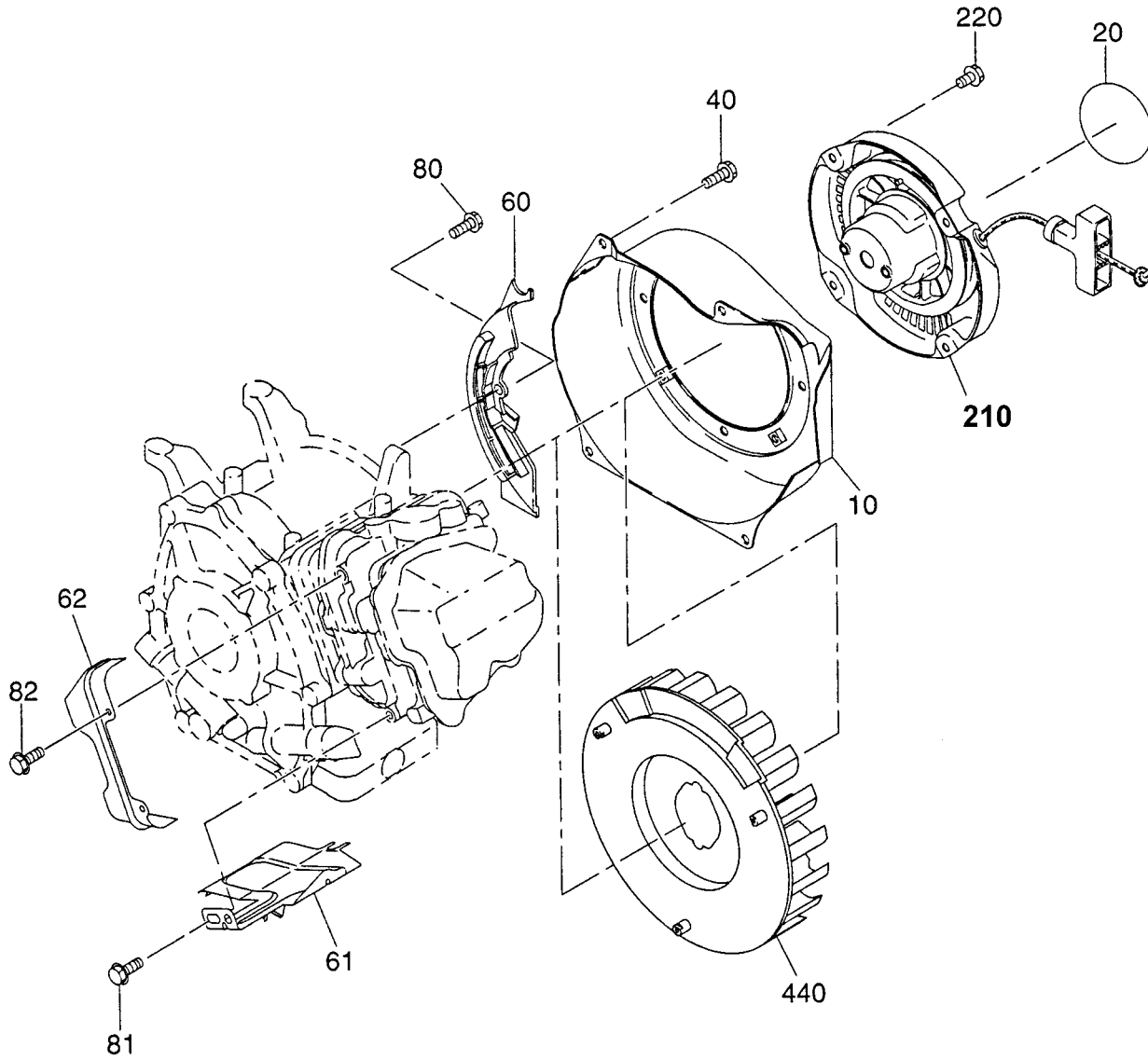

SECTION 5 COOLING and STARTING GROUP

FIG. 510

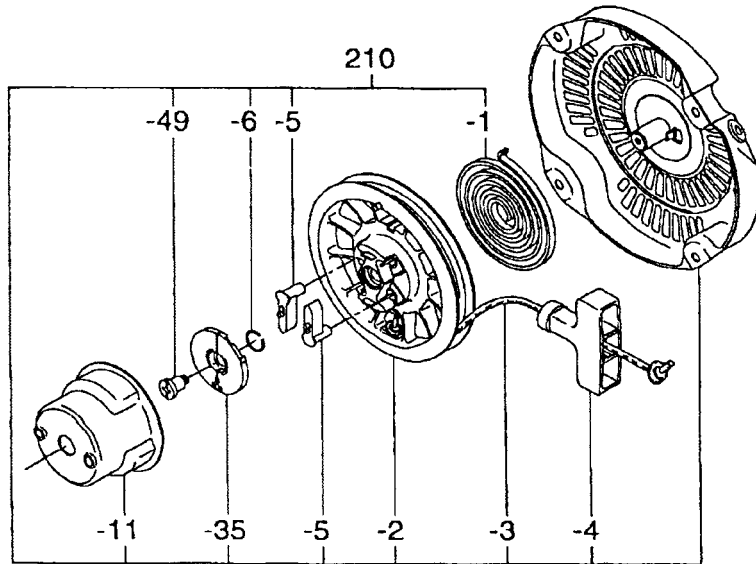

SECTION 6 FUEL, LUBRICATION GROUP

FIG. 600

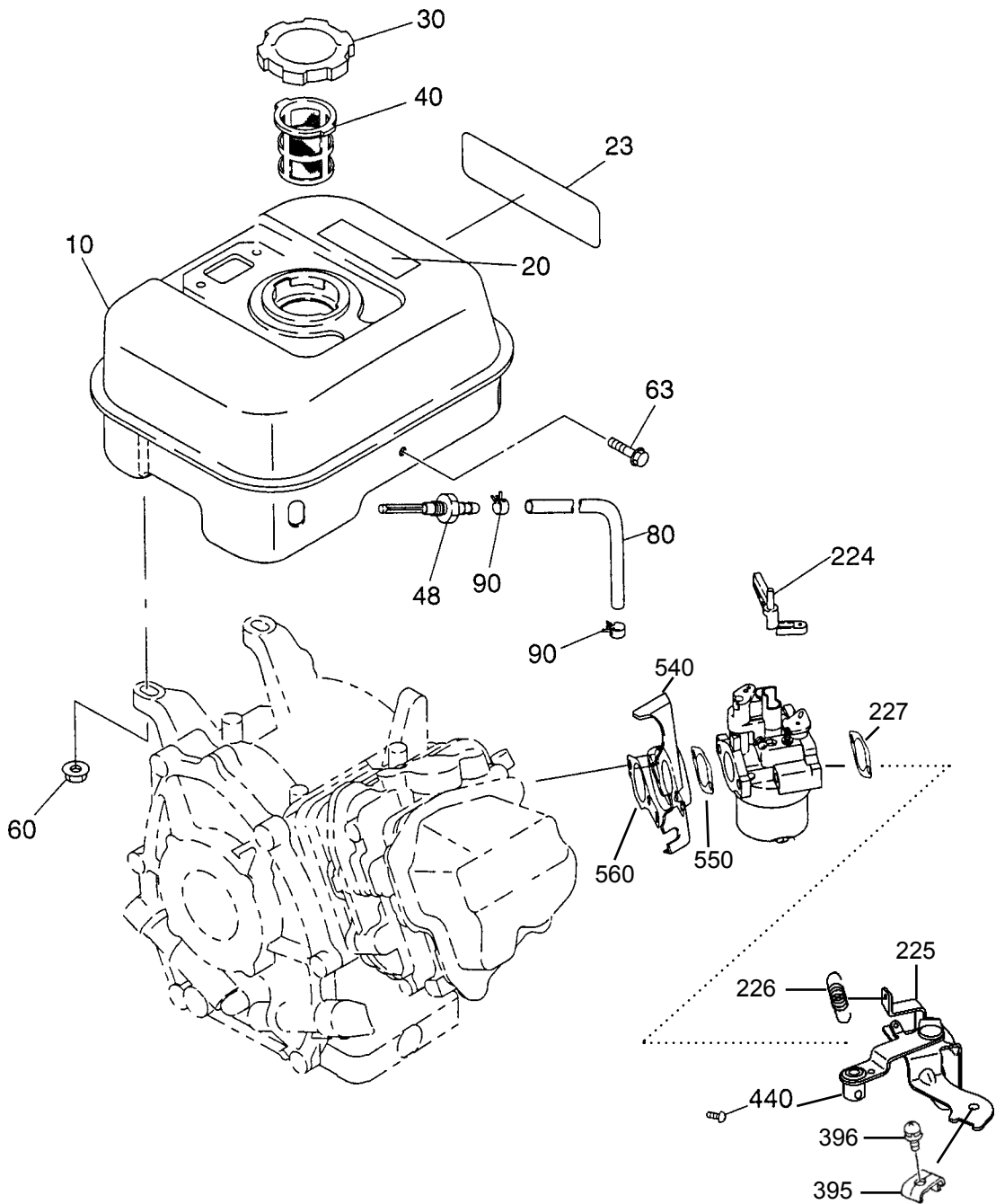

SECTION 6 FUEL, LUBRICATION GROUP

FIG. 610

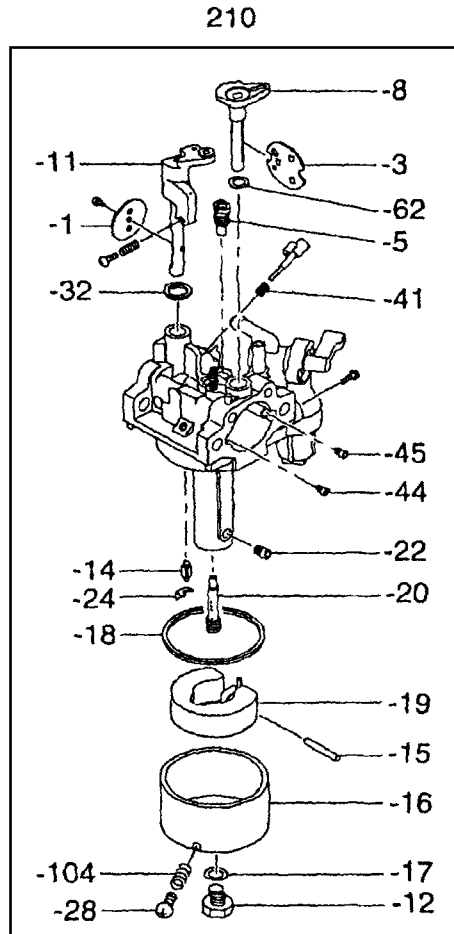

SECTION 6 FUEL, LUBRICATION GROUP

REF.	PART NO.	DESCRIPTION	QTY.	REMARKS	FROM-TO	FIG.
210	276-62301-10	CARBURETOR	1	EX13, Foam		610
	276-62302-10	CARBURETOR	1	EX13, Dual Element		610
	276-62304-20	CARBURETOR	1	EX13, Low Profile		610
210	277-62301-10	CARBURETOR	1	EX17, Foam		610
	277-62302-10	CARBURETOR	1	EX17, Dual Element		610
	277-62304-20	CARBURETOR	1	EX17, Low Profile		610
	277-62303-00	CARBURETOR	1	EX17, Cyclone Pre-Cleaner		610
210	278-62301-10	CARBURETOR	1	EX21, Foam		610
	278-62302-10	CARBURETOR	1	EX21, Dual Element		610
	278-62304-20	CARBURETOR	1	EX21, Low Profile		610
-1	106-62538-08	THROTTLE VALVE	1	EX13		610
	277-62535-08	THROTTLE VALVE	1	EX17, 21		610
-3	277-62525-08	CHOKE VALVE	1	Foam / Dual Element		610
	277-62527-08	CHOKE VALVE	1	Low Profile / Cyclone (17)		610
-5	246-62420-08	PILOT JET	1	EX13, 17		610
	278-62420-08	PILOT JET	1	EX21		610
-8	277-62520-08	CHOKE LEVER	1			610
	277-62560-08	CHOKE LEVER	1	Low Profile		610
-11	276-62530-08	THROTTLE SHAFT	1	EX13, Foam		610
	276-62531-08	THROTTLE SHAFT	1	EX13, Dual Element / Low Profile		610
-11	277-62530-08	THROTTLE SHAFT	1	EX17, 21, Foam		610
	277-62531-08	THROTTLE SHAFT	1	EX17,21, Dual Element / Low Profile		610
-12	227-62451-08	BOLT	1			610
-14	277-62500-08	NEEDLE	1			610
-15	277-62515-08	PIN	1			610
-16	277-62506-08	FLOAT BODY	1			610
-17	214-62450-08	PACKING	1			610
-18	214-62540-08	CHAMBER PACKING	1			610
-19	226-62506-08	FLOAT	1			610
-20	276-62440-08	MAIN NOZZLE	1	EX13		610
	277-62440-08	MAIN NOZZLE	1	EX17		610
	278-62440-08	MAIN NOZZLE	1	EX21		610
-22	277-62404-08	MAIN JET	1	EX13, Foam / Low Profile		610
	252-62405-08	MAIN JET	1	EX13, Dual Element		610
-22	277-62402-08	MAIN JET	1	EX17, Foam		610
	226-62412-08	MAIN JET	1	EX17, Dual Element		610
	277-62412-08	MAIN JET	1	EX17, Low Profile / Cyclone (17)		610
-22	278-62403-08	MAIN JET	1	EX21, Foam / Low Profile		610
	277-62405-08	MAIN JET	1	EX21, Dual Element		610
-24	226-62701-18	CLIP	1			610
-28	277-62360-08	BOLT	1			610
-32	246-62390-08	THROTTLE SEAL	1	Dual, Low Profile, Cyclone		610
-44	207-62410-08	AIR JET	1	EX13		610
	248-62410-08	AIR JET	1	EX17		610
	106-62411-08	AIR JET	1	EX21		610
-45	106-62410-08	AIR JET, PILOT	1			610

SECTION 6 FUEL, LUBRICATION GROUP

FIG. 610

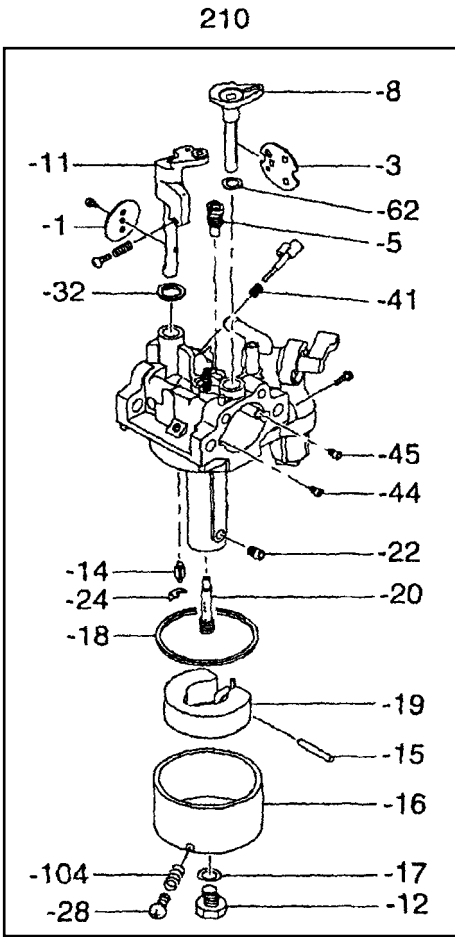

SECTION 7 ELECTRIC DEVICE GROUP

FIG. 700

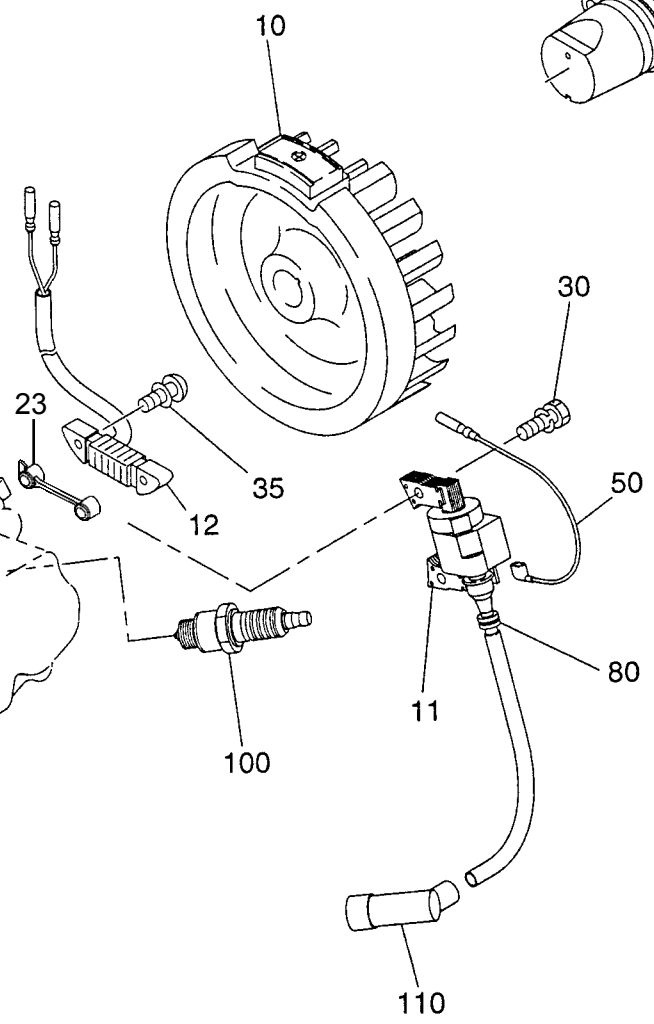
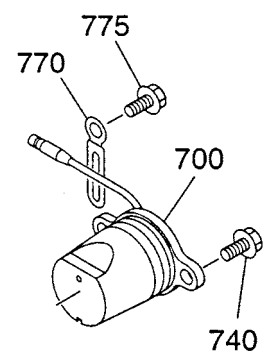
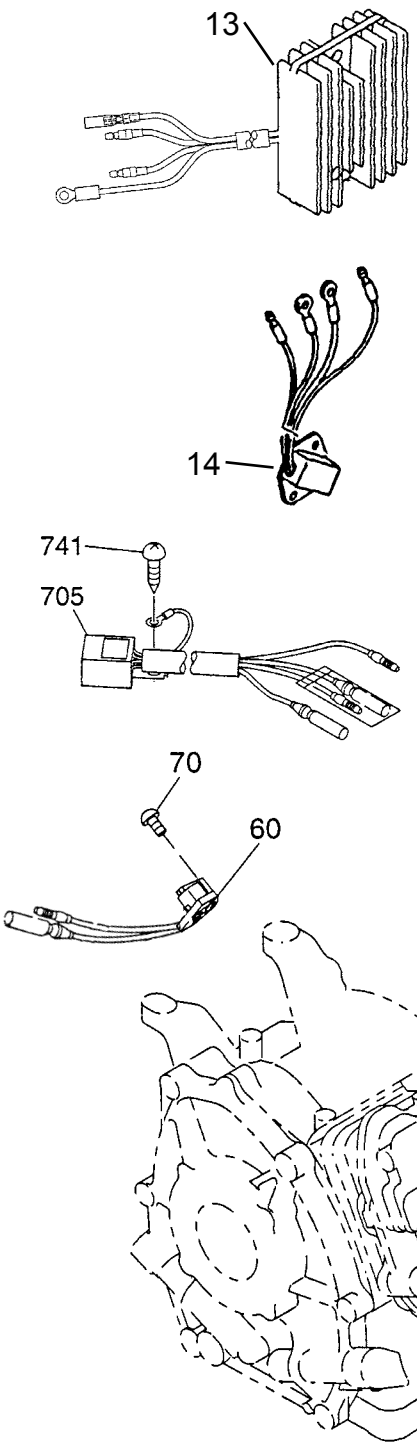
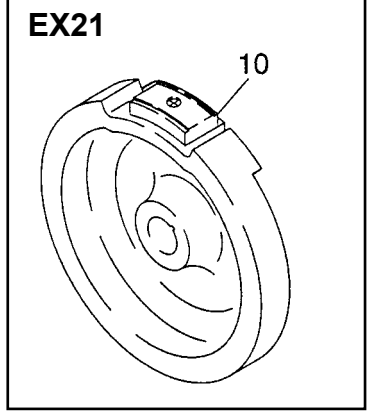
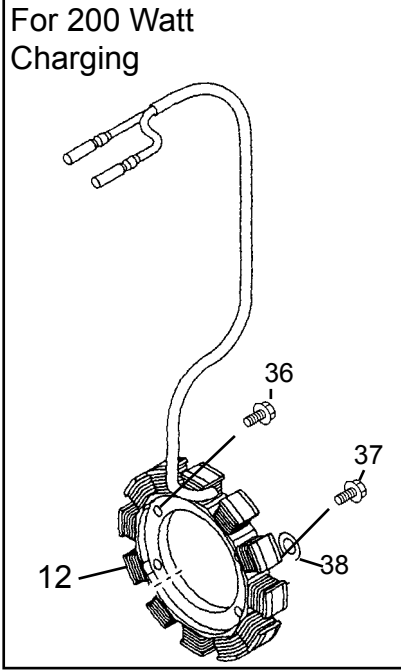

SECTION 7 ELECTRIC DEVICE GROUP

REF.	PART NO.	DESCRIPTION	QTY.	REMARKS	FROM-TO	FIG.
10	276-79230-11	FLYWHEEL CP	1	EX13 - STD		700
	276-79241-01	FLYWHEEL CP	1	EX13 - 15W, 40W Charging		700
10	277-79230-11	FLYWHEEL CP	1	EX17 - STD		700
	277-79241-01	FLYWHEEL CP	1	EX17 - 15W, 40W Charging		700
	277-79242-01	FLYWHEEL CP	1	EX17 - 200W Charging		700
	277-79251-01	FLYWHEEL CP	1	EX17 - 15W, 40W-Incl ring gear		700
	277-79252-01	FLYWHEEL CP	1	EX17 - 200W, w/ring gear		700
10	278-79240-21	FLYWHEEL CP	1	EX21 - STD		700
	278-79241-01	FLYWHEEL CP	1	EX21 - 15W & 40W Charging		700
	278-79243-01	FLYWHEEL CP	1	EX21 - 200W Charging		700
	278-79251-01	FLYWHEEL CP	1	EX21 - 15W, 40W-Incl ring gear		700
	278-79252-01	FLYWHEEL CP	1	EX21 - 200W, w/ring gear		700
11	277-79431-01	IGNITION COIL CP	1			700
12	277-79301-01	CHARGE COIL	1	EX13,17,21 - STD, 15W		700
	277-79302-01	CHARGE COIL	1	EX13,17,21 - 40Watt		700
	277-79303-01	CHARGE COIL	1	EX17,21 - 200Watt		700
13	277-71901-01	REGULATOR RECTIFIER	1	EX17,21 - 200Watt		700
14	247-71401-01	RECTIFIER DIODE	1	EX13,17,21 - 15W		700
	246-71903-01	RECTIFIER DIODE	1	EX17,21 - 40W		700
23	277-79501-03	SPACER	1	EX17,21 - 15W,40W Charging		700
30	001-14062-50	BOLT and WASHER AY	2			700
35	001-13063-50	BOLT	2	15W Charging - L=35mm		700
	001-13064-00	BOLT	2	40W Charging - L=40mm		700
36	004-35062-50	SCREW and WASHER	2	200W Charging - L=25mm		700
37	277-79001-03	REAMER SCREW	2	200W Charging		700
38	003-20060-00	SPRING WASHER	2	200W Charging		700
50	277-73102-H1	WIRE 2 CP	1	EX13,17,21 w/ oil sensor		700
	279-73105-H1	WIRE 5 CP	1	Electric Start		700
60	X66-00003-61	SWITCH AY	1	Old style		700
70	015-00400-90	TAPPING SCREW	2			700
80	024-10701-10	GROMMET	1			700
100	065-01401-50	SPARK PLUG	1			700
110	065-50002-70	SPARK PLUG CAP	1			700
700	277-76301-11	OIL SENSOR CP	1			700
705	KU3-11043-11	CONTROL AY, oil sensor	1			700
	KU3-11043-01	CONTROL AY, oil sensor	1	Old style		700
740	001-14061-60	BOLT and WASHER AY	2			700
741	015-00400-90	TAPPING SCREW	2			700
770	214-79006-01	CLAMP CP	1			700
775	011-00600-20	FLANGE BOLT	1			700

FIG. 710

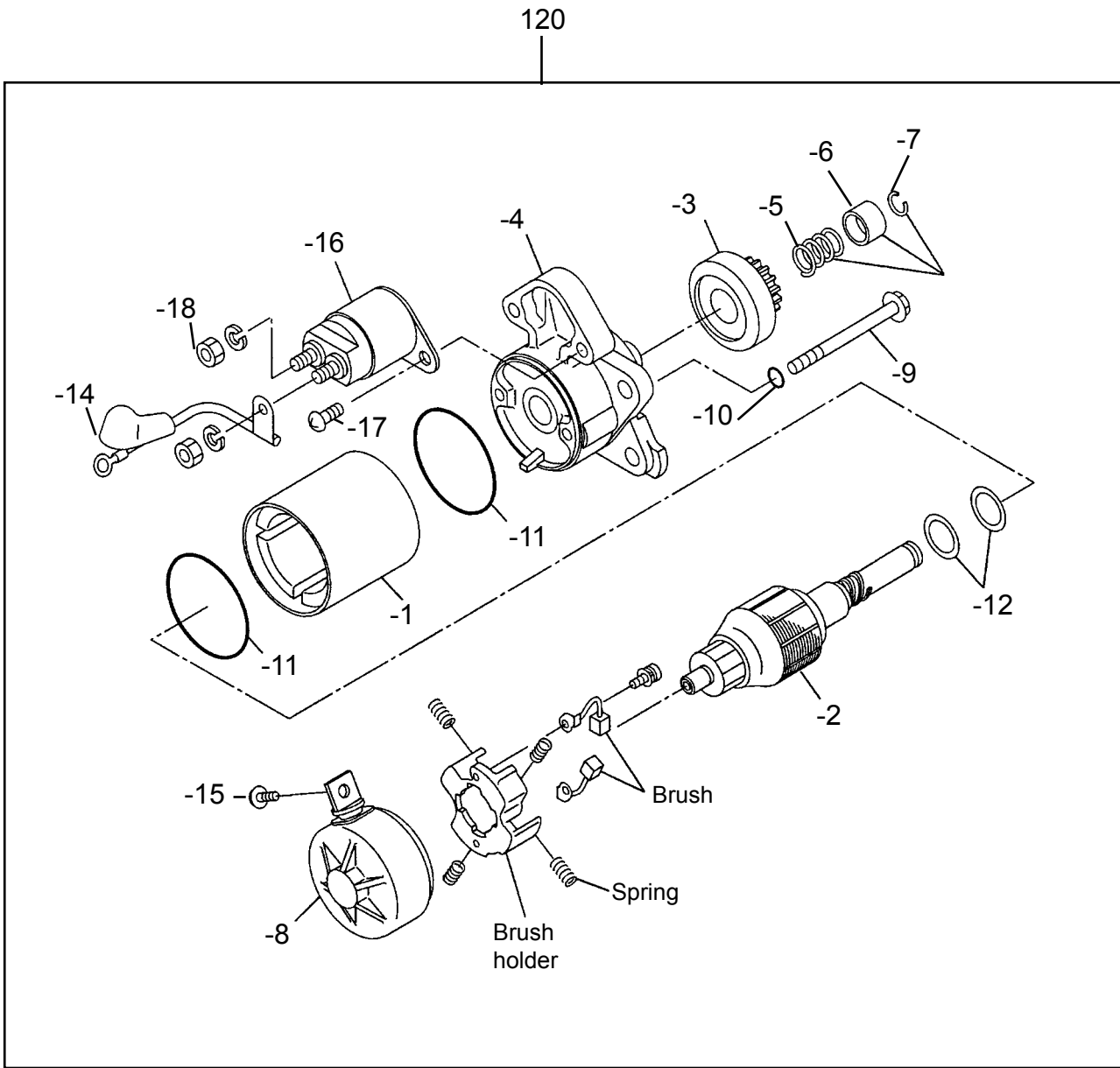

SECTION 7 ELECTRIC DEVICE GROUP - CONTROL BOX

FIG. 720

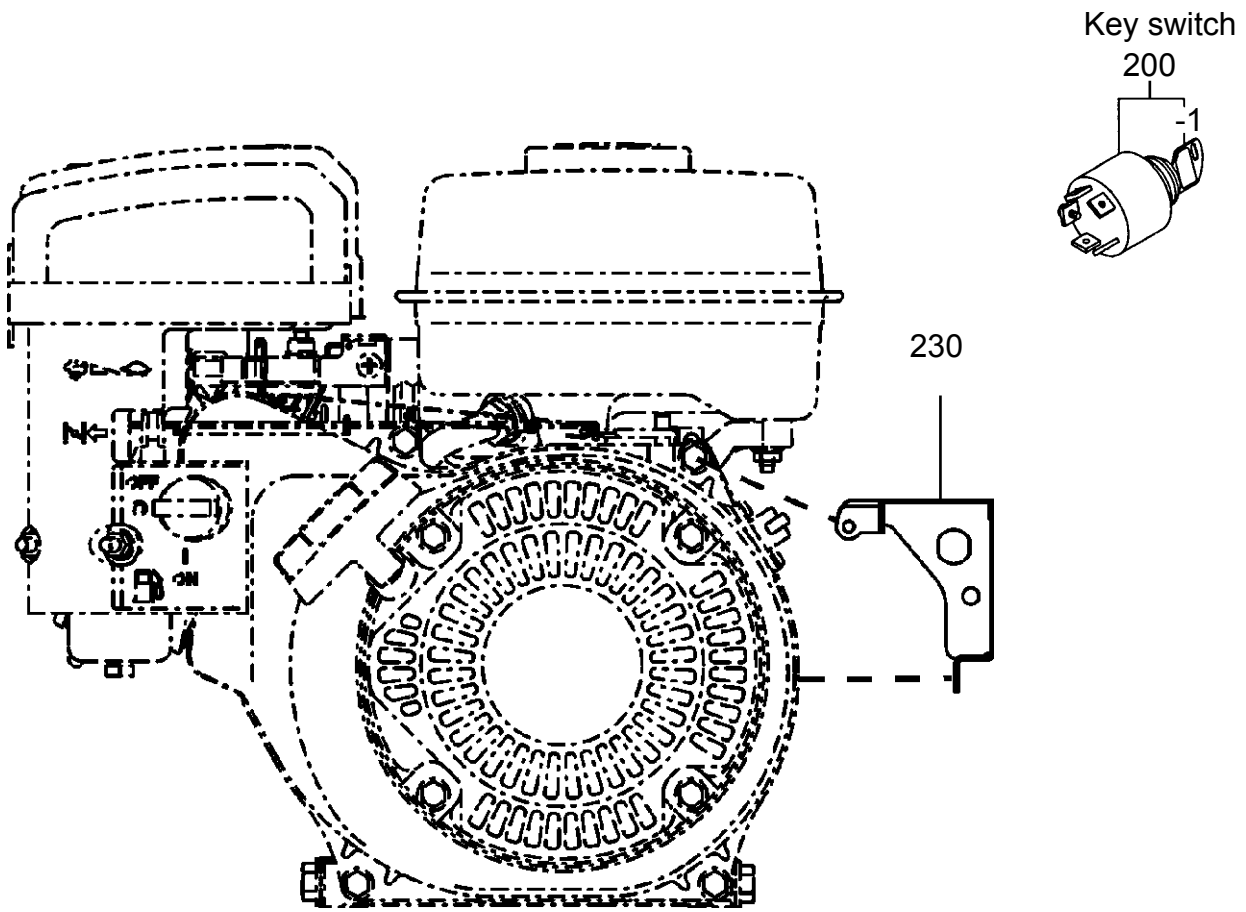

SECTION 9 ACCESSORY GROUP

FIG. 900

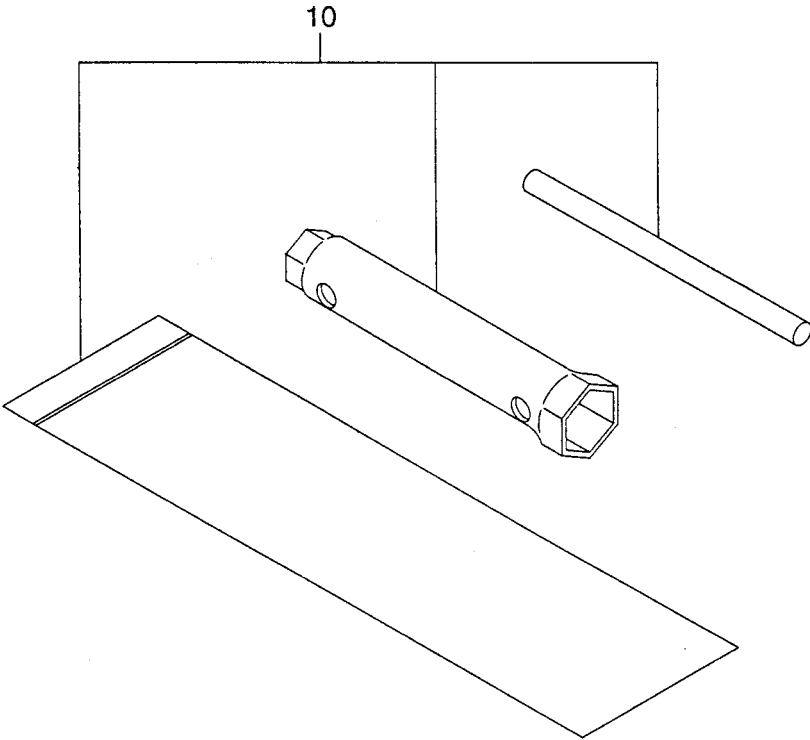

PRINTED IN THE USA