

## Para Ordenar Repuestos, Sírvase Llamar al Concesionario más Cercano a su Domicilio

Sírvase darnos la siguiente información:

- Número del modelo
- Código impreso
- Descripción y número del repuesto según la lista de repuestos

Puede escribirnos a:

Parts Department  
100 Production Drive  
Harrison, OH 45030 U.S.A.

No. de Ref.	Descripción	Número del Repuesto	Ctd.	No. de Ref.	Descripción	Número del Repuesto	Ctd.
1	Deflector del escape	SV490000AV	1	51	Cuerpo de la válvula inferior *	SV495300AV	1
2	Perno de cabeza hex. - M5 x 22	◇	4	52	Resorte del gatillo	□	1
3	Arandela de resorte - GB859-87	◇	6	53	Placa del gatillo	□	1
4	Cubierta de cabeza	○	1	54	Pasador de resorte - 2,5 x 16	□	1
5	Arandela de sello	○	1	55	Gatillo	□	1
6	Anillo en O	○	1	56	Pasador del gatillo	□	1
7	Reestimiento interno	SV490600AV	1	57	Anillo en O	□	1
8	Anillo en O	○	1	58	Buje	SV496000AV	1
9	Resorte de compresión	●	1	59	Resorte de torsión	SV496100AV	1
10	Válvula de equilibrio	●	1	60	Seguro de liberación rápida	SV496200AV	1
11	Anillo en O	○	1	61	Perno de cabeza hex. - M4 x 12	◇	1
12	Anillo en O	○	1	62	Cubierta del botón	SV496400AV	1
13	Anillo en O	○	1	63	Cargador B	SV496500AV	1
14	Anillo en O	○	1	64	Impulsor	◆	1
15	Anillo	■	1	65	Soporte del resorte	◆	2
16	Piston	■	1	66	Resorte de empuje	◆	2
17	Alabe del impulsor	■	1	67	Cargador A	SV496900AV	1
18	Collar *	■	1	68	Arandela de resorte - GB857-87	◇	1
19	Anillo en O	○	1	69	Perno de cabeza hex. - M3 x 12	◇	1
20	Anillo en O	○	1	70	Tornillo de cabeza plana - M3 x 12	◇	1
21	Cilindro *	SV491900AV	1	71	Tope del extremo del cargador	SV497300AV	1
22	Defensa	SV492000AV	1	72	Almohadilla del cargador	SV497400AV	1
23	Empaque	○	1	73	Pasador de resorte	SV497500AV	1
24	Cubierta de la boquilla	SV473100AV	1	74	Resorte	SV497600AV	1
25	Cuerpo	No disponible	1	75	Botón del seguro del cargador	SV497700AV	1
26	Boquilla *	SV492600AV	1	76	Pasador de resorte	SV497800AV	1
27	Guía del impulsor	SV492700AV	1	77	Gancho de cola *	SV497900AV	1
28	Perno de cabeza hex. - M4 x 16	◇	2	78	Perno de cabeza hex.	SV498000AV	2
29	Separador *	SV492900AV	1	79	Cubierta de la concavidad del extremo	SV498100AV	1
30	Perno de cabeza hex. - M5 x 22	◇	2	80	Mango	SV498200AV	1
31	Ensamble de la guía del impulsor	▼	1	81	Anillo en O	○	1
32	Pasador	SV493400AV	1	82	Capacete *	SV473000AV	1
33	Anillo en O	SV493500AV	1				
34	Marco de la guía de control de profundidad	△	1				
35	Resorte de seguridad	△	1				
36	Cuerpo de la guía de control de profundidad	△	1				
37	Bola de acero	△	1				
38	Resorte	△	2				
39	Ruedecilla	△	1				
40	Elemento de contacto superior	△	1				
41	Elemento de contacto inferior	SV494300AV	1				
42	Punta de protección	SV494400AV	1				
43	Arandela de resorte - GB859-87	◇	3				
44	Perno de cabeza hex. - M4 x 16	◇	1				
45	Sello interno	○	1				
46	Cuerpo de la válvula superior	SV494800AV	1				
47	Resorte interno del gatillo	SV494900AV	1				
48	Anillo en O	▲	2				
49	Embolo de la válvula del gatillo	SV495100AV	1				
50	Anillo en O	▲	1				

4 sp

# TASK FORCE® 2-in-1 Nailier/Stapler Clouuse/agrafeuse 2-en-1 Clavadora/Engrapadora 2-en-1

Replacement Parts Manual  
Manuel de pièces de rechange  
Lista de Repuestos

TFN10400AV

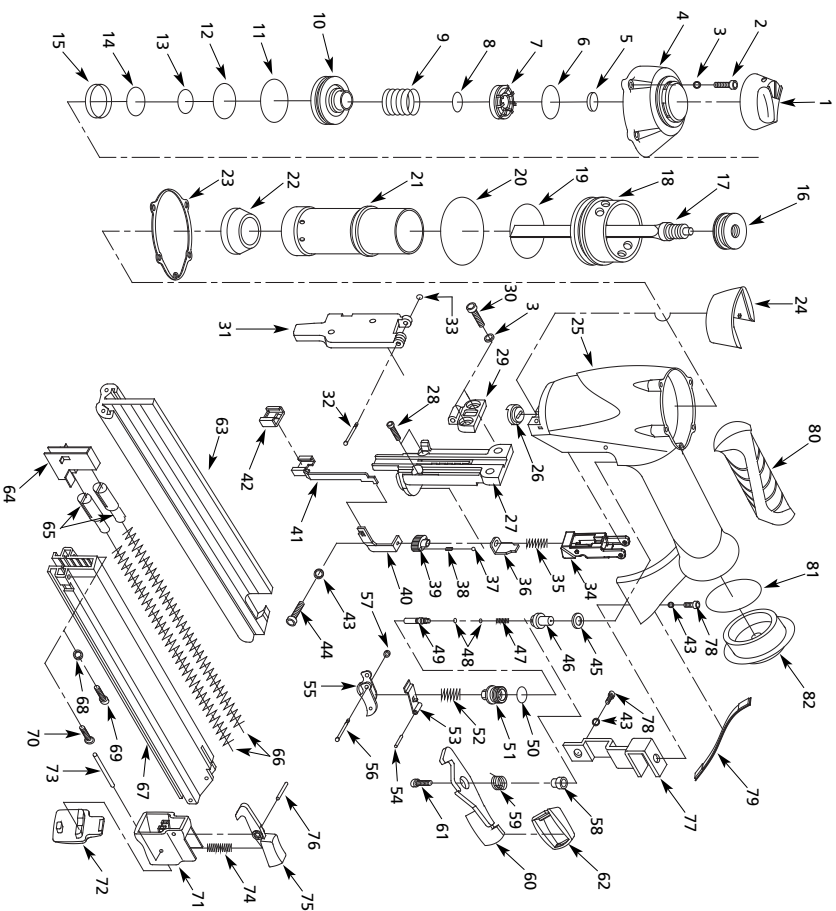

**For Replacement Parts, call 1-800-543-6400**

Please provide following information:  
 - Model number  
 - Serial number (if any)  
 - Part description and number as shown in parts list

Address parts correspondence to:  
 Parts Department  
 100 Production Drive  
 Harrison, OH 45030 U.S.A.

Ref. No.	Description	Part Number	Qty.
1	Exhaust deflector	SV490000AV	1
2	Hex. socket head bolt - M5 x 22	◇	4
3	Spring washer - GB859-87	◇	6
4	Head cap	Not Available	1
5	Seal washer	○	1
6	O-ring	○	1
7	Internal lining	SV490600AV	1
8	O-ring	●	1
9	Compression spring	●	1
10	Balance valve	●	1
11	O-ring	○	1
12	O-ring	○	1
13	O-ring	○	1
14	O-ring	●	1
15	Ring	○	1
16	Piston	■	1
17	Driver blade	■	1
18	Collar *	SV491600AV	1
19	O-ring	○	1
20	O-ring	○	1
21	Cylinder *	SV491900AV	1
22	Bumper	SV492000AV	1
23	Gasket	○	1
24	Nozzle shield	SV473100AV	1
25	Body	Not Available	1
26	Nozzle *	SV492600AV	1
27	Driver guide	SV492700AV	1
28	Hex. socket head bolt - M4 x 16	◇	2
29	Spacer *	SV492900AV	1
30	Hex. socket head bolt - M5 x 22	◇	2
31	Driver guide assembly	▼	1
32	Pin	SV493400AV	1
33	O-ring	SV493500AV	1
34	Depth control guide frame	△	1
35	Safety spring	△	1
36	Depth control guide body	△	1
37	Steel ball	△	2
38	Spring	△	2
39	Thumbwheel	△	1
40	Upper work contact element	△	1
41	Lower work contact element	SV494300AV	1
42	No-mar tip	SV494400AV	1
43	Spring washer - GB859-87	◇	1
44	Hex. socket head bolt - M4 x 16	◇	3
45	Inner seal	○	1
46	Upper valve body	SV494800AV	1
47	Inner trigger spring	SV494900AV	1
48	O-ring	▲	2
49	Trigger valve plunger	SV495100AV	1
50	O-ring	▲	1

Ref. No.	Description	Part Number	Qty.
51	Lower valve body *	SV495300AV	1
52	Trigger spring	□	1
53	Trigger plate	□	1
54	Spring pin - 2.5 x 16	□	1
55	Trigger	□	1
56	Pin for trigger	□	1
57	O-ring	□	1
58	Bushing	SV496000AV	1
59	Torsion spring	SV496100AV	1
60	Quick release latch	SV496200AV	1
61	Hex. socket head bolt - M4 x 12	◇	1
62	Button cover	SV496400AV	1
63	Magazine B	SV496500AV	1
64	Pusher	◆	1
65	Spring holder	◆	2
66	Pusher spring	◆	2
67	Magazine A	SV496900AV	1
68	Spring washer - GB857-87	◇	1
69	Hex. socket head bolt - M3 x 12	◇	1
70	Flat head screw - M3 x 12	◇	1
71	Magazine end stop	SV497300AV	1
72	Magazine pad	SV497400AV	1
73	Spring pin	SV497500AV	1
74	Spring	SV497600AV	1
75	Magazine latch button	SV497700AV	1
76	Spring pin	SV497800AV	1
77	Tail hanger *	SV497900AV	1
78	Hex. socket head bolt - M4 x 8	◇	2
79	End hollow cover	SV498100AV	1
80	Hand grip	SV498200AV	1
81	O-ring	○	1
82	End cap *	SV473000AV	1

Standard hardware item - available at your local hardware store  
 Required 6 - 8 week lead time necessary for order

**REPLACEMENT PARTS KITS**

◆	Pusher assembly	SKN00900AV
◆	Trigger valve o-ring kit	SKN01000AV
◆	Driver kit	SKN01600AV
◆	Balance valve assembly	SKN01200AV
○	Trigger assembly	SKN01300AV
□	Complete o-ring replacement kit	SKN01700AV
▼	Driver guide assembly	SKN05200AV
△	Depth control assembly	SKN05600AV

**Pour pièces de rechange, appeler 1-800-543-6400**

S'il vous plaît fournir l'information suivante:  
 - Numéro de Modèle  
 - Numéro de série (s'il y a lieu)  
 - Description et numéro de la pièce

Correspondance:  
 Parts Department  
 100 Production Drive  
 Harrison, OH 45030 U.S.A.

N° de Réf.	Description	N° de Pièce	Qté.
1	Déflecteur d'échappement	SV490000AV	1
2	Boulon barillet hex - M5 x 22	◇	4
3	Rondelle élastique - GB859-87	◇	6
4	Chapeau de tête	Pas disponible	1
5	Rondelle d'étranchéité	○	1
6	Joint torique	○	1
7	Doubleur intérieur	SV490600AV	1
8	Joint torique	○	1
9	Resort de compression	●	1
10	Soupape d'équilibrage	●	1
11	Joint torique	○	1
12	Joint torique	○	1
13	Joint torique	○	1
14	Joint torique	●	1
15	Bague	○	1
16	Piston	■	1
17	Lame d'entraînement	■	1
18	Collier *	SV491600AV	1
19	Joint torique	○	1
20	Joint torique	○	1
21	Cylindre *	SV491900AV	1
22	Paré-chocs	SV492000AV	1
23	Joint d'étranchéité	○	1
24	Écran de buse	SV473100AV	1
25	Corps	Pas disponible	1
26	Guide *	SV492600AV	1
27	Guide d'entraînement	SV492700AV	1
28	Boulon barillet hex - M4 x 16	◇	2
29	Entroisee *	SV492900AV	1
30	Boulon barillet hex - M5 x 22	◇	2
31	Assemblage de la guide de entraînement	▼	1
32	Goupille	SV493400AV	1
33	Joint torique	SV493500AV	1
34	Cadre du guide de contrôle de profondeur	△	1
35	Resort de sécurité	△	1
36	Corps du guide de contrôle de profondeur	△	1
37	Bille d'acier	△	2
38	Resort	△	2
39	Mollette	△	1
40	Pointe de contact supérieur	△	1
41	Pointe de contact inférieur	SV494300AV	1
42	Embout anti-marque	SV494400AV	1
43	Rondelle élastique - GB859-87	◇	3
44	Boulon barillet hex - M4 x 16	◇	1
45	Scellement intérieur	○	1
46	Corps de soupape supérieur	SV494800AV	1
47	Resort intérieur de gâchette	SV494900AV	1
48	Joint torique	▲	2
49	Plongeur de soupape de gâchette	SV495100AV	1
50	Joint torique	▲	1

Article normal de quincaillerie - disponible à votre quincaillerie locale  
 Cette commande exige un préavis de 6 à 8 semaines

**REPLACEMENT PARTS KITS**

◆	Poussoir équipé	SKN00900AV
◆	Trousse de joint torique de soupape de gâchette	SKN01000AV
◆	Nécessaire d'entraînement	SKN01600AV
●	Montage de soupape d'équilibrage	SKN01200AV
○	Gâchette équipée	SKN01300AV
□	Nécessaire de rechange complet de joints toriques	SKN01700AV
▼	Assemblage de la guide de entraînement	SKN05200AV
△	Montage de contrôle de profondeur	SKN05600AV