



SERIOUS DUTY

Vertical Air Compressor Compresseur D'Air Vertical Compressore De Aire Vertical

Replacement Parts List
Liste De Pièces De Rechange
Lista De Repuestos

VS500702
VS500802

For parts, products & service information visit

POWER XPERT
www.chpower.com

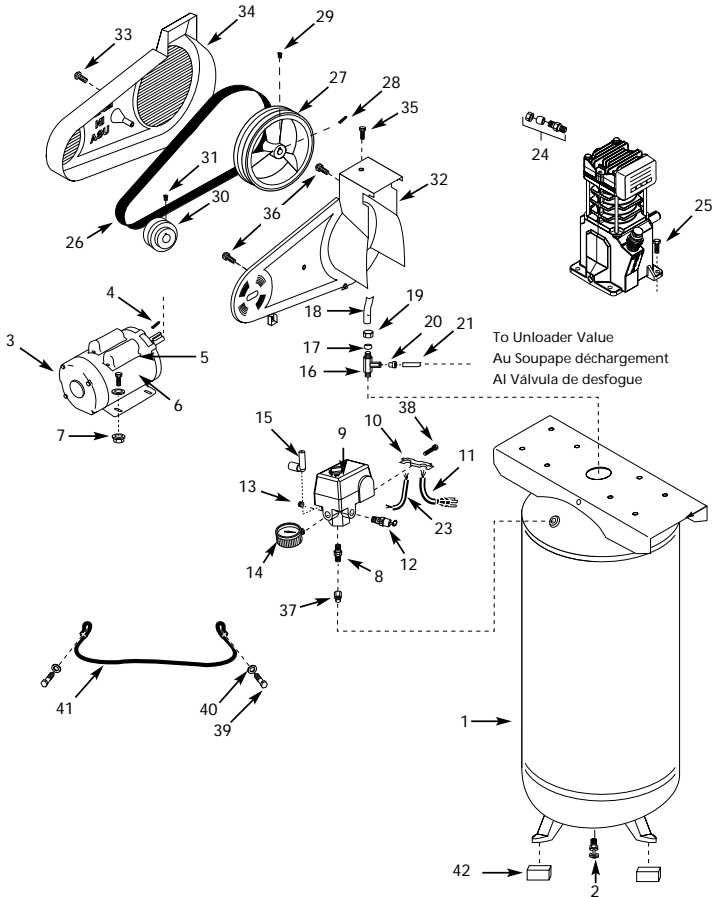

For Replacement Parts, Call 1-800-543-6400
Pour Pièces De Rechange, Composer le 1-800-543-6400
Para ordenar repuestos, sírvase llamar al distribuidor más cercano a su domicilio

Address parts correspondence to:
Correspondance:
Puede escribirnos a:
The Campbell Group
Attn: Parts Dept.
100 Production Drive
Harrison, OH 45030 U.S.A.

Please provide the following information:
-Model number
-Serial number (if any)
-Part description and number as shown in parts list

S'il vous plait fournir l'information suivant:
-Numéro du modèle
-Numéro de série (s'il y en a un)
-Description de la pièce et son numéro sur la liste

Sírvase darnos la siguiente información:
-Número del modelo
-Número de serie (de haberlo)
-Descripción y número del repuesto según la lista de repuestos

Ref. No.	Description	Description	Descripción	VS500702	VS500802	Qty. Qté. Ctd.
1	Tank	Réservoir	Tanque	AR040200BR	AR040200BR	1
2	Drain cock	Robinet de vidaange	Llave de salida	ST127700AV	ST127700AV	1
3	Electric motor	Moteur électrique	Motor eléctrico	MC018100AJ	MC018100AJ	1
4	3/16" sq. x 1.44" Key	Clavette 3/16 po sq. x 1 po	Chaveta de 4,8 mm (3/16") sq. x 2,54 cm (1")	KE000903AV	KE000903AV	1
5	5/16"-18 Hex head screw	Vis à tête hexagonale 5/16 po-18	Tornillo de cabeza hex de 7,9 mm (5/16")-18	ST016000AV	ST016000AV	4
6	5/16" Washer	Rondelle 5/16 po	Arandela de 7,9 mm (5/16")	ST011200AV	ST011200AV	4
7	5/16"-18 Locknut	Ecrou de serrage 5/16 po-18	Tuerca de seguridad de 7,9 mm (5/16")-18	ST146000AV	ST146000AV	4
8	1/4" Nipple	Raccord 1/4 po	Niple de 6,4 mm (1/4")	HF002401AV	HF002401AV	1
9	Pressure switch	Manostat	Presostato	CW208700AJ	CW208700AJ	1
10	Strain relief	Soulagement de fatigue	Relevo de tensión	CW209500AV	CW209500AV	1
11	Power cord and plug	Cordon et fiche	Cordón y enchufe	EC012601AV	EC012601AV	1
12	ASME Safety valve	Soupape de sureté ASME	Válvula de seguridad ASME	V-215100AV	V-215100AV	1
13	Plug	Bouchon	Enchufe	ST022500AV	ST022500AV	1
14	Gauge	Manomètre	Manómetro	GA016700AV	GA016700AV	1
15	Unloader valve	Soupape de déchargement	Válvula de desfogue	CW210000AV	CW210000AV	1
16	Check valve	Clapet	Válvula de chequeo	CV221502AJ	CV221502AJ	1
17	Ferrule	Virole	Manga	ST067300AV	ST067300AV	1
18	Discharge tube	Tuyau de refoulement	Tubo de descarga	VS020800AP	VS020800AP	1
19	Compression nut	Ecrou de compression	Tuerca de compresión	ST033001AV	ST033001AV	1
20	Push-in fitting	Raccord enfichable	Ajuste de empuje	ST081301AV	ST081301AV	1
21	Unloader tube	Tuyau de déchargeur	Tube del descargador	ST117802AV	ST117802AV	1
22	Pump	Pompe	Bomba	VS260000KB	VS260000KB	1
23	Motor cord	Cordon du moteur	Cordón del motor	EC012800AV	EC012800AV	1
24	Compression assembly	Assemblage de compression	Ensamblaje de compresión	ST019300AV	ST019300AV	1
25	5/16"-12 x 3/4" Self-tapping screw	Vis autoforeuse 5/16 po-12 x 3/4 po	Tornillo autorroscante de 7,9 mm (5/16")-12 x 19,1 mm (3/4")	ST016500AV	ST016500AV	4
26	Belt	Courroie	Banda	BT002800AV	BT002800AV	1
27	Flywheel		Volant	PU004900BK	PU004900BK	1
28	3/16" x 1" Key	Clavette 3/16 po x 1 po	Chaveta de 4,8 mm (3/16") sq. x 2,54 cm (1")	KE000900AV	KE000900AV	1
29	3/8"-16 x 3/4" Setscrew	Vis de pression 3/8 po-16 x 3/4 po	Tornillo de 9,5 mm (3/8")-16 x 19,1 mm (3/4")	ST026200AV	ST026200AV	1
30	Pulley	Poulie	Polea	PU012600AG	PU012600AG	1
31	1/4"-20 x 1/2" Square head set screw	Vis de pression a tête carré 1/4 po-20 x 1/2 po	Tornillo de cabeza cuadrada de 6,4 mm (1/4")-20 x 12,7 mm (1/2")	ST012200AV	ST012200AV	1
32	Belt guard (back)	Carter de courroie (arrière)	Tapa protectora de bandas (posterior)	BG217902AV	BG217902AV	1
33	Plascrew	Vis	Tornillo	ST058502AV	ST058502AV	1
34	Belt guard (front)	Carter de courroie (avant)	Tapa protectora de bandas (frontal)	BG217800AV	BG217800AV	1
35	5 mm x 25 mm Self-tapping screw	Vis autoforeuse 5 mm x 25 mm	Tornillo autorroscante de 5 mm x 25 mm	ST073269AV	ST073269AV	1
36	10-24 x 5/16" Self-tapping screw	Vis autoforeuse 10-24 x 5/16 po	Tornillo autorroscante de 10-24 x 7,9 mm (5/16")	ST042400AV	ST042400AV	3
37	Reducer	Raccord de réduction	Reductor	ST071428AV	ST071428AV	1
38	Strain relief screw	Vis de soulagement de tension	Tornillo del relevo de tensión	ST209800AV	ST209800AV	1
39	Lag bolt	Tire-fond	Tornillo de fiador	ST080502AV	ST080502AV	2
40	Washer	Rondelle	Arandela	ST070914AV	ST070914AV	2
41	Safety cable	Cable de sûreté	Cable de seguridad	ST178900AJ	ST178900AJ	1
42	Isolation pad	Tampons isolateur	Almohadillas aislantes	ST179000AV	ST179000AV	3
43	Δ Warning decal (3 piece)	Décalomanie d'avertissement (3 pièces)	Etiquetas de advertencia (3)	DK630000AV	DK630000AV	1
44	Δ Inspection port reducer 1/2" x 3/8"	Raccord de réduction de porte de inspection 1/2 po x 3/8 po	Reductor de orificio de inspección 3,81 cm x 9,5 mm (1/2" x 3/8")	PG150007AV	PG150007AV	1
45	Δ Inspection port o-ring	Joint torique de porte de inspection	Anillo en o para el orificio de inspección	ST070191AV	ST070191AV	2
46	Δ Inspection port plug 1/2"	Bouchon de porte de inspection 1/2 po	Conector de orificio de inspección 3,81 cm (1/2")	PG150004AV	PG150004AV	1
Δ	Not shown	Pas indiquée	No se muestra			