

Notes

Notas



Two Cylinder Air Compressor
Compresseur d'Air à Deux Cylindres
Compresores de Aire de Dos Cilindros

Replacement Parts List
Liste de Pièces de Rechange
Lista de Repuestos

VT761X and VT781X Series
Series VT761X et VT781X
Serie VT761X y VT781X

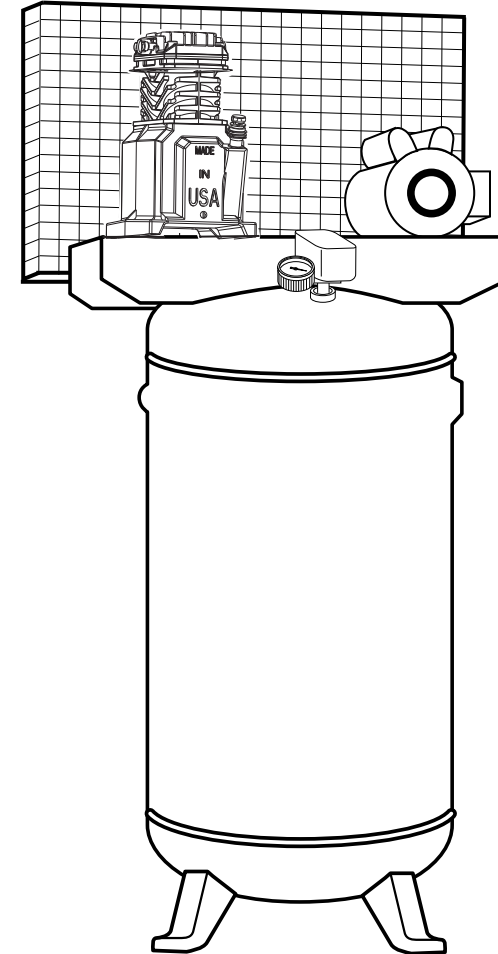

For Replacement Parts, call 1-800-543-6400

Pour Pièces de Rechange, appeler 1-800-543-6400

Para ordenar repuestos, comuníquese con el distribuidor de productos Campbell Hausfeld más cercano a su domicilio

Please provide following information:
- Model number
- Serial number (if any)
- Part description and number as shown in parts list

S'il vous plaît fournir l'information suivant:
- Numéro du modèle
- Numéro de série (si applicable)
- Description de la pièce et son numéro sur la liste de pièces

Sírvase suministrar la siguiente información:
- Número del Modelo
- Número de Serie (de haberlo)
- Descripción y número del repuesto según la lista de repuestos

Address parts correspondence to:	The Campbell Group
Correspondance concernant les pièces:	Attn: Parts Department 100 Production Drive Harrison, OH 45030 USA
Puede escribirnos a:	

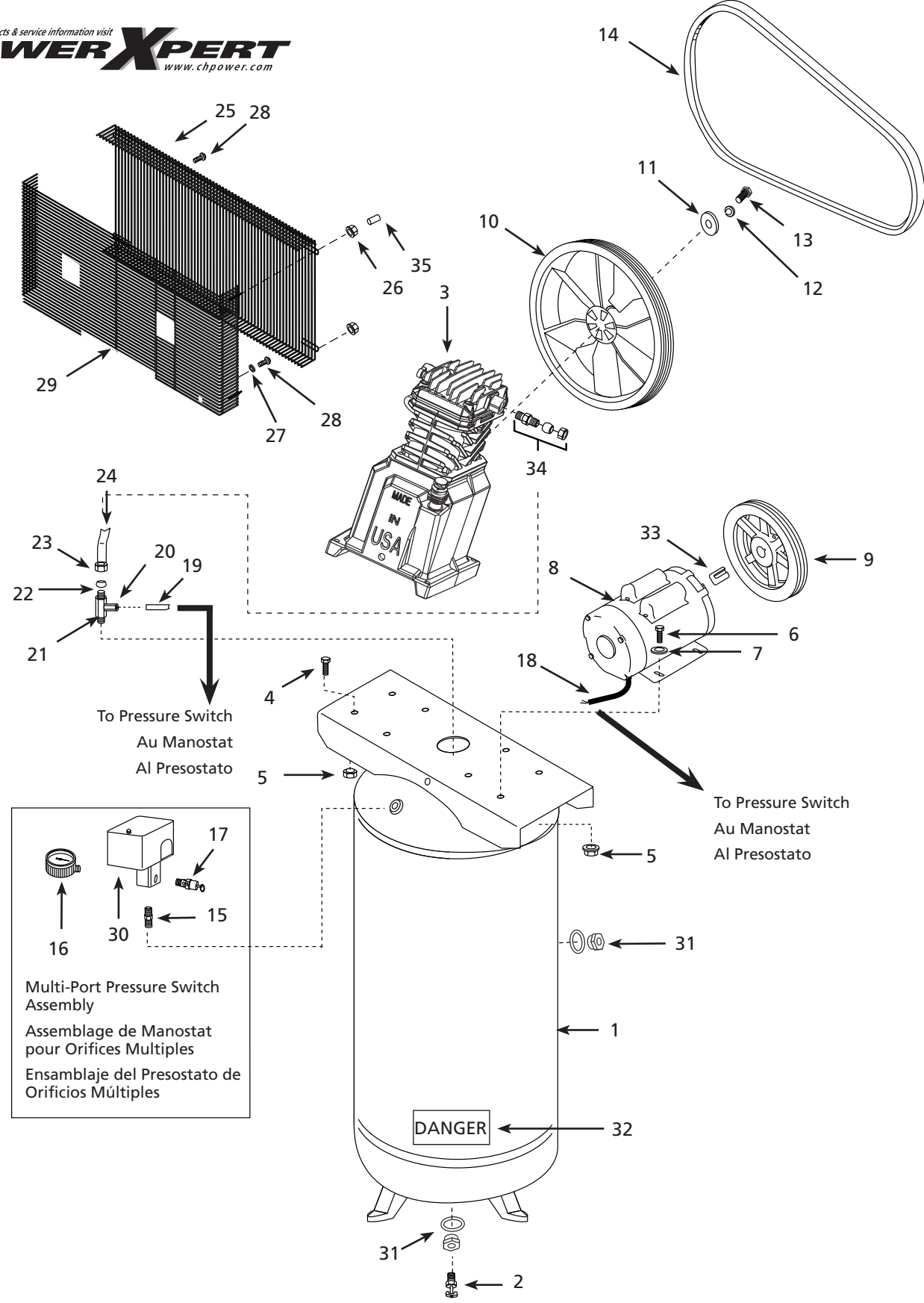

Multi-Port Pressure Switch Assembly
Assemblage de Manostat pour Orifices Multiples
Ensamblaje del Presostato de Orificios Múltiples

To Pressure Switch
Au Manostat
Al Presostato

To Pressure Switch
Au Manostat
Al Presostato

For Replacement Parts, Call 1-800-543-6400 Pour Pièces de Rechange, appeler 1-800-543-6400

Para ordenar repuestos, comuníquese con el distribuidor de productos Campbell Hausfeld más cercano a su domicilio

Address parts correspondence to:
Correspondance concernant les pièces:

Puede escribirnos a:
The Campbell Group
Attn: Parts Department
100 Production Drive
Harrison, OH 45030 USA

Please provide following information:

-Model number
-Serial number (if any)
-Part description and number as shown in parts list

S'il vous plait fournir l'information suivante:

-Numéro du modèle
-Numéro de série (si applicable)
-Description de la pièce et son numéro sur la liste de pièces

Sírvase suministrar nos la siguiente información:

- Número del Modelo
- Número de Serie (de haberlo)
- Descripción y número del repuesto según la lista de repuestos

Ref. No.	Description	Description	VT761X and VT781X Series Series VT761X et VT781X Serie VT761X y VT781X	Qty. Qté. Ctd.
1	Crankcase	Carter	VT050100AG	1
2	Oil seal	Bague d'étanchéité	ST120000AV	1
3	Crankshaft assembly (Includes bearings)	Montage de vilebrequin (Paliers compris)	VT050300AJ	1
4	O-ring	Joint torique	ST164405AV	1
5	Bearing cap	Chapeau de palier	VT050200AV	1
6	Dipstick breather	Reinfiard de la réglette-jauge	VT041703AV	1
7	Crankcase gasket	Joint d'étanchéité	XA011100AV	1
8	Cylinder	Cylindre	VT040700AG	1
9	Cylinder gasket	Joint de cylindre	XA011900AV	1
10	Connecting rod/piston/rings assembly kit	Nécessaire de montage de bielle/piston/bagues	TQ010900AJ	2
11	Piston ring kit	Nécessaire de segments de piston	TQ900700AJ	2
12	Valve plate assembly	Montage de plaque de soupape	VT470800AJ	1
13	Cylinder head	Culasse	VT040400AG	1
14	Head/cylinder fastener kit	Nécessaire d'attache de culasse/cylindre	TQ900800AJ	1
15	Standard Filter	Filtre Standard	MP333200AJ	1
	Deluxe Filter	Filtre Deluxe	ST073915AV	1
16	Standard filter element	Cartouche filtrante standarde	ST042500AV	1
	Heavy duty filter element	Cartouche filtrante robuste	ST163100AV	1
17	Belt guard bracket	Support de carter de courroie	TQ012000AV	1
18	O-ring	Joint torique	ST164406AV	1
19	Gasket	Joint d'étanchéité	TQ011200AV	1
20	1/4" NPT Plug	Bouchon mâle 1/4 po NPT	ST072917AV	1
■	Gasket kit (Includes Nos. 4, 7, 9, 18 & 19)	Nécessaire de joints d'étanchéité (Compris Nos. 4, 7, 9, 18 & 19)	TQ901000AJ	1

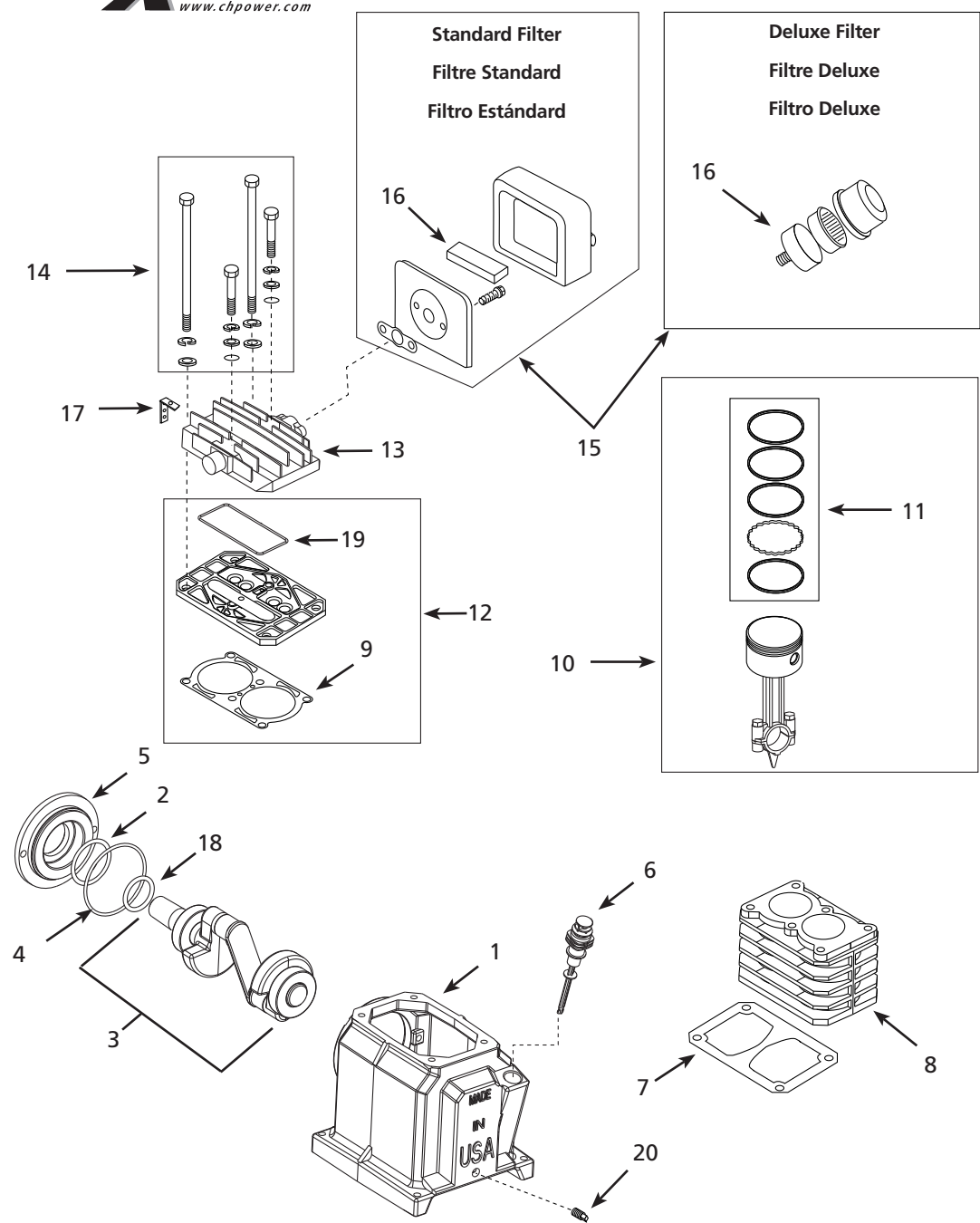

Bolt Torques	
Connecting rods	80 in/lbs
Bearing cap	100 in/lbs
Head	200 in/lbs

Couple de Boulons	
Bielles	92,24 kg cm
Chapeau de palier	115,3 kg cm
À tête	230,6 kg cm

Torques en los Pernos	
Biela	92,24 kg cm
Tapa de los cojinetes	115,3 kg cm
Cabezal	230,6 kg cm

For Replacement Parts, Call 1-800-543-6400

Please provide following information:
 -Model number
 -Serial number (if any)
 -Part description and number as shown in parts list

Address parts correspondence to:
 The Campbell Group
 Attn: Parts Department
 100 Production Drive
 Harrison, OH 45030

Ref. No.	Description	VT761X and VT781X Series	Qty.
1	Air tank - 60 gallon	AR233300CG	1
	Air tank - 80 gallon	TF006607CG	1
2	Drain cock	D-1401	1
3	Air compressor pump w/o flywheel	VT700900AJ	1
4	5/16" - 18 x 1 1/2" Hex head bolt	ST012100AV	4
5	5/16" -18 Locknut	ST146000AV	4
6	5/16" -18 x 3/4" Hex head bolt	ST016000AV	4
7	5/16" Washer	ST011200AV	4
8	Electric motor	MC302400AV	1
9	Motor pulley	PU009788AV	1
10	Flywheel	PU016402AV	1
11	Washer	ST124200AV	1
12	Lock washer	ST071012AV	1
13	7/16" Torque bolt	TF058100AV	1
14	Belt - 60 gallon	BT009800AV	1
	Belt - 80 gallon	BT008100AV	1
15	Pipe nipple	HF002401AV	1
16	Pressure gauge	GA031000AV	1
17	Safety valve	V-215105AV	1
18	Electric cord	EC013500AV	1
19	Tubing	ST117802AV	1
20	Straight push connect	ST119301AV	1
21	Check valve	CV221502AJ	1
22	1/2" Compression sleeve	ST032900AV	1
23	1/2" Compression nut	ST033001AV	1
24	Discharge tube	VT050400AP	1
25	Front beltguard	BG217002AJ	1
26	10-24 Hex-flange nut	ST116201AV	5
27	5/16" Washer	ST011200AV	2
28	5/16" Self-tapping screw	ST016500AV	2
29	Back beltguard	BG217100AJ	1
30	Pressure switch	CW207574AV	1
31	Tank plugs		
	2" - 3/4" Reducing bushing	PG201002AV	1
	2" - 1/4" Reducing bushing	PG201004AV	1
	O-ring	ST070190AV	2
32	Tank warning decals	DK634000AJ	1
33	Key	KE000900AV	1
34	Compression fitting	ST018300AV	1
35	Cap	ST075400AV	5

Pour Pièces de Rechange, appeler 1-800-543-6400

S'il vous plaît fournir l'information suivant:

- Numéro du modèle
- Numéro de série (si applicable)
- Description de la pièce et son numéro sur la liste de pièces

Correspondance concernant les pièces:

The Campbell Group
Attn: Parts Department
100 Production Drive
Harrison, OH 45030 USA

No. Ref.	Description	Series VT761X et VT781X	Qté.
1	Réservoir d'air - 227.1 L	AR233300CG	1
	Réservoir d'air - 302.8 L	TF006607CG	1
2	Robinet de vintage	D-1401	1
3	Pompe de compresseur d'air sans volant	VT700900AJ	1
4	Boulon à tête hexagonale 5/16 po - 18 x 1 1/2 po	ST012100AV	4
5	Écrou de blocage 5/16 po - 18	ST146000AV	4
6	Boulon à tête hexagonale 5/16 po - 18 x 3/4 po	ST016000AV	4
7	Rondelle 5/16 po	ST011200AV	4
8	Moteur électrique	MC302400AV	1
9	Poulie de moteur	PU009788AV	1
10	Volant	PU016402AV	1
11	Rondelle	ST124200AV	1
12	Rondelle-frein	ST071012AV	1
13	Boulon de couple 7/16 po	TF058100AV	1
14	Courroie - 227.1 L	BT009800AV	1
	Courroie - 302.8 L	BT008100AV	1
15	Mamelon de tuyau	HF002401AV	1
16	Manomètre	GA031000AV	1
17	Soupape de sûreté	V-215105AV	1
18	Cordon d'alimentation	EC013500AJ	1
19	Tube	ST117802AV	1
20	Raccord poussoir droit	ST119301AV	1
21	Clapet	CV221502AJ	1
22	Manchon de compression 1/2 po	ST032900AV	1
23	Écrou de compression 1/2 po	ST033001AV	1
24	Tuyau de décharge	VT050400AP	1
25	Carter de courroie (Avant)	BG217002AJ	1
26	Écrou à collet 10-24	ST116201AV	5
27	Rondelle 5/16 po	ST011200AV	2
28	Vis à tête 5/16 po	ST016500AV	1
29	Carter de courroie (Arrière)	BG217100AJ	1
30	Manostat	CW207574AV	1
31	Bouchons de réservoir		
	Bague de reduction, 2 po - 3/4 po	PG201002AV	1
	Bague de reduction, 2 po - 1/4 po	PG201004AV	1
	Joint torique	ST070190AV	2
32	Décalcomanies d'avertissement pour réservoir	DK634000AJ	1
33	Clé	KE000900AV	1
34	Raccord de compression	ST018300AV	1
35	Capuchon	ST075400AV	5

Para ordenar repuestos, comuníquese con el distribuidor de productos Campbell Hausfeld más cercano a su domicilio

Sirvase suministrarnos la siguiente información:

- Número del Modelo
- Número de Serie (de haberlo)
- Descripción y número del repuesto según la lista de repuestos

Puede escribirnos a:

The Campbell Group
Attn: Parts Department
100 Production Drive
Harrison, OH 45030 USA

No. de Ref.	Descripción	Serie VT761X y VT781X	Ctd.
1	Tanque de aire - 227.1 L	AR233300CG	1
	Tanque de aire - 302.8 L	TF006607CG	1
2	Llave de drenaje	D01401	1
3	Cabezal del compresor de aire sin el volante	VT700900AJ	1
4	Perno de cabeza hex. de 7,9 mm (5/16") - 18 x 3,81 cm (1 1/2")	ST012100AV	4
5	Tuerca de seguridad de 7,9 mm (5/16") - 18	ST146000AV	4
6	Perno de cabeza hex. de 7,9 mm (5/16") - 18 x 19,1 mm (3/4")	ST016000AV	4
7	Arandela de 7,9 mm (5/16")	ST011200AV	4
8	Motor eléctrico	MC302400AV	1
9	Polea del motor	BT009800AV	1
10	Volante	PU011104AV	1
11	Arandela	ST124200AV	1
12	Arandela de seguridad	ST071012AV	1
13	Perno de torque de 11,1 mm (7/16")	TF058100AV	1
14	Banda - 227.1 L	BT009800AV	1
	Banda - 302.8 L	BT008100AV	1
15	Niple para tuberías	HF002401AV	1
16	Manómetro	GA031000AV	1
17	Válvula de seguridad	V-215105AV	1
18	Cordón eléctrico	EC013500AV	1
19	Tube	ST117802AV	1
20	Conector a presión	ST119301AV	1
21	Válvula de chequeo	CV221502AJ	1
22	Manga de compresión de 12,7 mm (1/2")	ST032900AV	1
23	Tuerca de compresión de 12,7 mm (1/2")	ST033001AV	1
24	Tube de descarga	VT050400AP	1
25	Tapa frontal de las bandas	BG217002AJ	1
26	Tuerca hex. #10-24	ST116201AV	5
27	Arandela de 7,9 mm (5/16")	ST011200AV	2
28	Tornillo autorroscante de 7,9 mm (5/16")	ST016500AV	1
29	Tapa posterior de las bandas	BG217100AJ	1
30	Presostato	CW207574AV	1
31	Conectores para el tanque		
	Buje reductor de 5,08 cm - 19,1 mm (2" - 3/4")	PG201002AV	1
	Buje reductor de 5,08 cm - 6,4 mm (2" - 1/4")	PG201004AV	1
	Anillo en O	ST070190AV	2
32	Etiquetas de advertencia del tanque	DK634000AJ	1
33	Chaveta	KE000900AV	1
34	Conector (sistema de compresión)	ST018300AV	1
35	Tapa	ST075400AV	5