

Please read and save these instructions. Read carefully before attempting to assemble, install, operate or maintain the product described. Protect yourself and others by observing all safety information. Failure to comply with instructions could result in personal injury and/or property damage! Retain instructions for future reference.



HVLP Spray Gun

EXTREME DUTY™

Attention: Campbell Hausfeld recommends authorized service facilities perform services not shown in instruction manual

Table Of Contents

Description1
 Unpacking1
 General Safety Information1-2
 Setup & Preparation2-3
 Operation3-4
 Maintenance4
 Troubleshooting5-6
 Ordering Replacement Parts7-8
 Warranty8

Description

High volume, low pressure (HVLP) paint sprayers are designed to deliver a fine finish with low overspray. The sprayer can be used to apply various acrylics, stains, sealers, lacquers, latexes, and primers. This unit can be used for painting cabinets, furniture, machinery, equipment, walls and trim work. Sprayers of this type are not recommended for automotive final coat. This portable unit is an ideal alternative to conventional spray guns. The HVLP's high transfer efficiency provides professional results with much less material waste and environmental contamination than other conventional spray painting systems.

Unpacking

When unpacking the sprayer, inspect carefully for any damage that may have occurred during transit. Make sure any loose fittings, bolts, etc., are tightened before putting sprayer into service. Each sprayer has been tested before shipment.

NOTE: The packing nut may need additional adjustment due to the packing material relaxing during shipment.

The fluid used for testing the sprayer has been drained, but some of this fluid will remain in the spray gun. This fluid should be flushed from the spray gun to prevent contamination of the coating material.

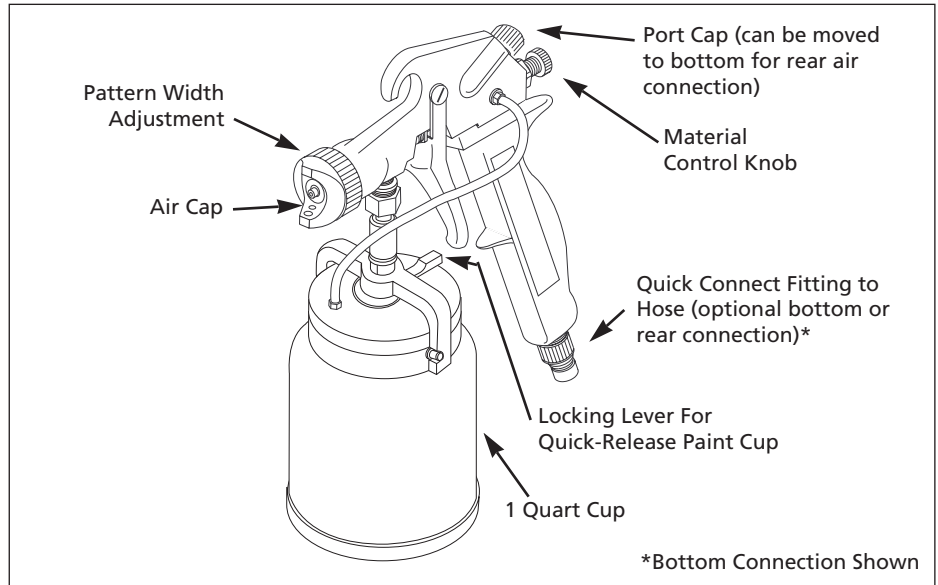

Figure 1 - Features

Use a solvent compatible with the coating to be sprayed.

General Safety

⚠ DANGER Danger indicates an imminently hazardous situation which, if not avoided, WILL result in death or serious injury.

⚠ WARNING Warning indicates a potentially hazardous situation which, if not avoided, COULD result in death or serious injury.

⚠ CAUTION Caution indicates a potentially hazardous situation which, if not avoided, MAY result in minor or moderate injury.

⚠ NOTICE Notice indicates important information, that if not followed, may cause damage to equipment.

Read all instructions and safety precautions before operating the unit.



⚠ WARNING

Risk of fire or explosion! Solvent and paint fumes can explode or ignite, causing severe injury and property damage.



Paints and solvents containing HALOGENATED HYDROCARBONS can react explosively with aluminum. Always check the product's label before using these materials in the unit.

Make sure the room is well-ventilated.

Avoid all ignition sources, such as static electricity sparks, open flames, hot objects, sparks from connecting and disconnecting power cords, and working light switches.

Follow the material and solvent manufacturers' safety precautions and warnings. Do not use liquids with flash points less than 100° F (38° C).

General Safety (Continued)

Do not carry TURBINE while spraying.

Keep the turbine at maximum distance from spraying area.

Static electricity can be produced by HVLP spraying. Make sure any electrically conductive object being sprayed is grounded to prevent static sparking. The sprayer is grounded through the electric cord. If an extension cord is necessary, the cord must be a grounded, 115 volt, three wire type cord.

Hazardous vapors: Paints, solvents, insecticides, and other materials may be harmful if inhaled causing severe nausea, fainting or poisoning.



Always use a respirator or mask. Read all instructions with the mask to ensure the mask will provide necessary protection against inhalation of harmful vapors.

NEVER point spray gun at any part of the body or at anyone else.

CAUTION

Tipping gun causes clogs. Dried spray material also clogs pressure delivery tube and fittings. The spray gun will not function when clogged.

When not in use, be sure to disconnect hose and place gun on a solid, level surface to avoid tipping.

Components

- (1) Gun - fully assembled, with 1.00 mm "all purpose" needle/nozzle installed
- (1) .75 mm "fine" needle/nozzle - located in storage compartment

Setup

NEEDLE AND NOZZLE ASSEMBLY

IMPORTANT: The needle and nozzle are a matched assembly. It is very important that both the needle and nozzle are correctly selected and installed. The needle/nozzle kits are identified by a number inscribed on each component. Make sure the numbers on the nozzle and the needle match. Failure to match these two components will result in poor finish quality.

1. Remove retaining ring, air cap, air flow ring, nozzle, material control knob, spring, and needle assembly (Fig. 2).
2. Install appropriate needle/nozzle assembly selected for material to be sprayed.
3. Reassemble needle assembly, spring, material control knob, nozzle, air flow ring, air cap, and retainer ring.

NOTICE

The four raised knobs on the air flow ring must be facing forward when assembled.

4. Attach quick connect fitting to hose.

ADJUSTING PACKING

Occasionally the packing nut, located in front of the trigger assembly, will require adjustment. The packing nut also requires adjustment when needle/nozzle assembly is changed.

1. Turn material control knob clockwise at least 3/4 of the way in.
2. Use wrench to tighten packing nut. Turn clockwise until the needle will not return to the closed position when trigger is released. Do not overtighten packing nut.
3. Loosen packing nut (approx. 1/4 turn) until needle returns freely to the closed position.

Preparation

PREPARING TO SPRAY

Some manufacturers do not recommend thinning their materials. In general, these instructions apply only when a brush or roller is used. Thinning may be necessary if materials are to be sprayed. Check with paint supplier for specific details when purchasing spray material.

Be sure to stir material thoroughly after adding a thinning agent and before checking the viscosity. Failure to properly mix material results in a poor finish.

NOTICE: Some latex finishes are very thick and require a great amount of thinning and mixing. Add a latex paint conditioner (available at most home centers) to the paint to improve spray performance.

1. Strain paint before spraying. Unstrained paint may affect material flow and spray pattern. When spraying thin materials such as lacquer or stains, consult with material supplier for proper strainer mesh number.
2. Pour material into paint cup. Fill cup only 1/2 to 3/4 full if thinning is required. (See Figure 3). Refer to Chart 1 for proper thinning instructions.

NOTICE

Follow material manufacturer's recommendation for proper thinning agent.

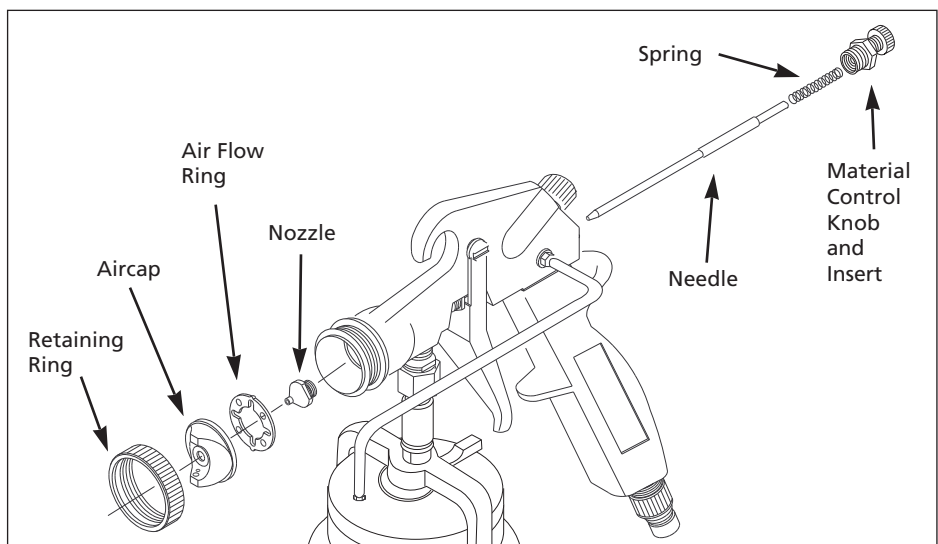

Figure 2 - Needle/Nozzle Installation

Preparation (Continued)

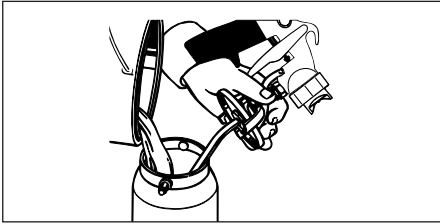

Figure 3 - Filling Paint Cup

- Using the following procedure, check viscosity of spray material before locking gun onto the paint cup (Figure 4).

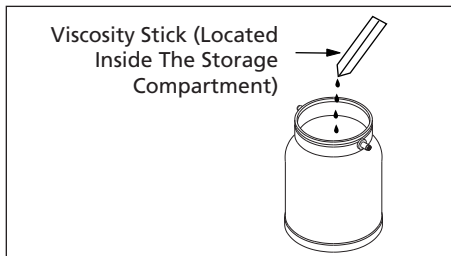

Figure 4 - Viscosity Stick

▲ NOTICE *The viscosity stick is located in storage compartment.*

- Dip viscosity stick into material. Remove stick from cup. Wait until the material stream becomes drips.
- Estimate the time interval between the first three drips. The time will vary depending on the thickness (viscosity) of the material.
- The material is adequately thinned if time interval is about one second.
- As a general rule, if the time between drips is more than one second, the material is too thick.

Add thinning agent, stir thoroughly and check again for proper viscosity.

- To tighten and lock the cup, place retainer arms securely around retaining pins on the paint cup.
- Move locking lever clockwise to locked position. (See Figure 5).

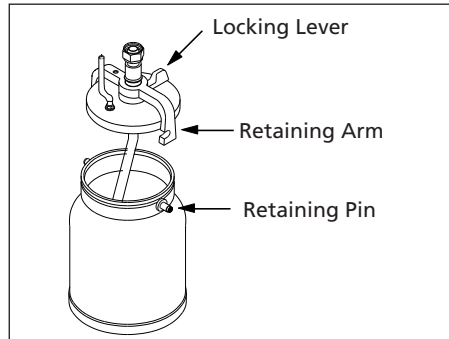

Figure 5 - Locking the cup

- Attach air hose quick-connect fitting to gun.

▲ NOTICE *The quick-connect fitting outer sleeve is spring loaded and must be pulled back to be attached or removed from the gun (Fig. 6).*

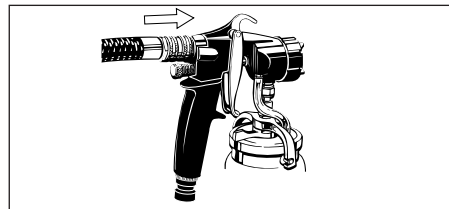

Figure 6 - Attaching Air Hose

Operation

Always practice before spraying in work area. Use cardboard to make gun adjustments if necessary.

- Keep gun parallel and 4" - 9" from surface of object being sprayed. (See Figure 7). If the material delivery is adjusted for a small narrow pattern, it may be necessary to move closer to the work surface.

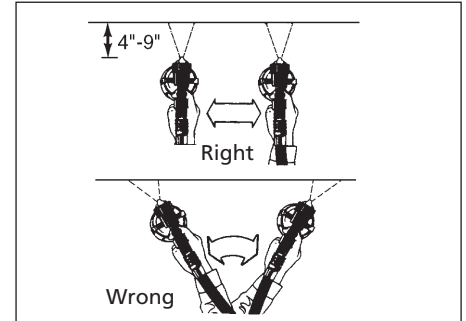

Figure 7 - Painting strokes

- Move gun in a smooth even stroke. Begin stroke before pulling trigger and continue the stroke after releasing trigger.
- For best results overlap each stroke by 25 to 50%.
- To adjust spray pattern, loosen retaining ring and turn air cap to desired pattern position (See Figure 8).

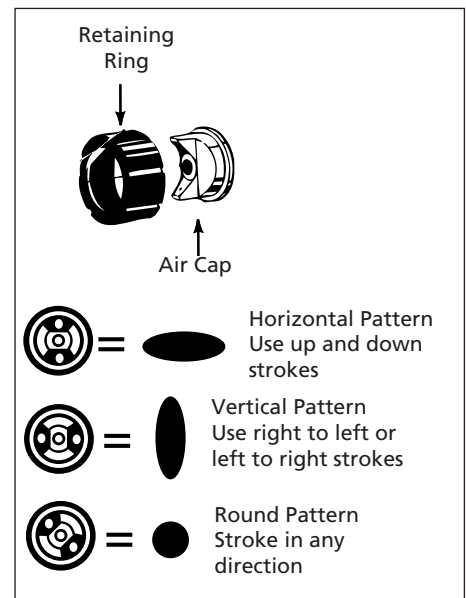

Figure 8 - Adjusting spray pattern

- To adjust material flow, turn material control knob clockwise to decrease and counterclockwise to increase (See Figure 9).

MATERIAL	PERCENT REDUCED	VISCOSITY IN SECONDS
Lacquers	25% - 50%	15 - 22 seconds
Sanding Sealer	20% - 30%	15 - 22 seconds
Enamels	20% - 40%	16 - 22 seconds
Stains (oil or water)	Use from can	15 seconds
Acrylic Enamel	50% - 60%	15 - 17 seconds
Catalyzed Polyurethane	10% - 30%	15 - 18 seconds
Polyurethanes, Varnishes	20% - 30%	16 - 22 seconds
Waterborne Coatings	0% - 10%	24 - 35 seconds

Chart 1

Operation (Continued)

- For fine pattern adjustment, turn air flow control knob clockwise to decrease and counterclockwise to increase air flow (See Figure 9).

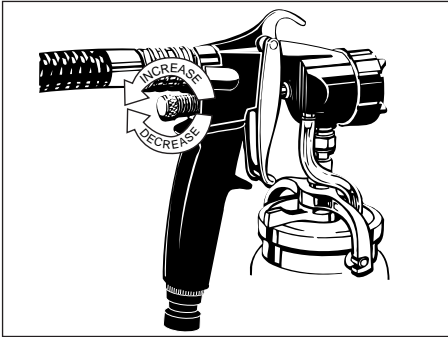

Figure 9 - Adjusting Material Flow

NOTE: Reducing air flow will reduce overspray.

▲ NOTICE *Air from the turbine can be used to blow dry areas too heavily coated or slow in drying.*

Air from the turbine is warm as a result of normal operation. Finish quality can be affected on hot, dry days due to premature drying of some coatings such as lacquer. Add retarding agents to the materials to avoid premature drying. Consult material supplier for proper retarding agent and mixing procedures.

Maintenance

CLEANING

▲ WARNING *Make sure working area is well ventilated when using solvents. Dispose of all materials properly in accordance with all local regulations*

- Remove material control knob, spring and needle. (Pull trigger to help remove the needle).

▲ NOTICE *Removing the needle prior to removing the nozzle will prevent needle damage.*

- Unscrew and remove retaining ring, air cap and air flow ring. Use supplied wrench to remove nozzle. The spring does not have to be removed.

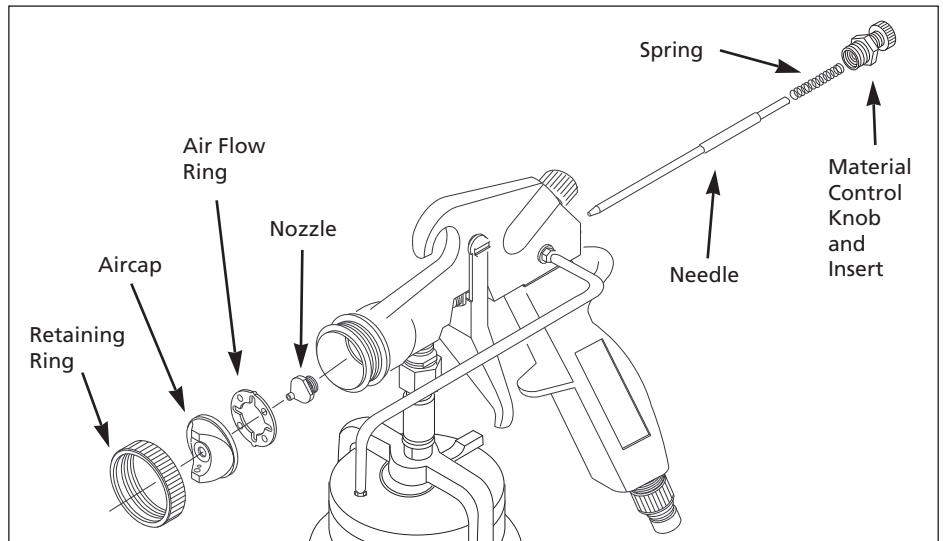

Figure 10 - Preparation for Cleaning

- Place the parts and the paint cup in a bucket or other suitable container. Soak in an appropriate solvent, or in soap and water if latex was used. To clean the gun, pour solvent through material tube until the solution clears (See Figure 11).

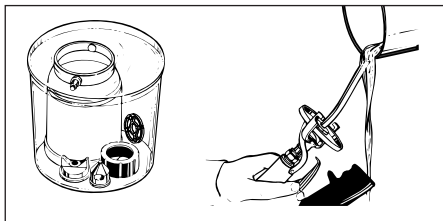

Figure 11 - Cleaning Spray Gun Parts

- Use cleaning brush (saturated with solvent) to clean material tube and nozzle (See Figure 12).

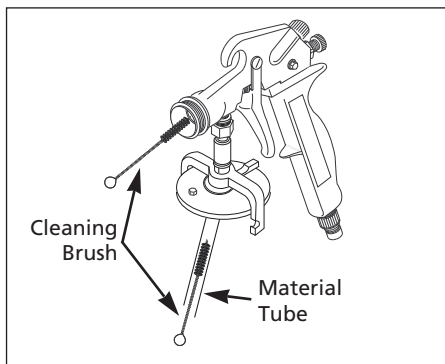

Figure 12 - Cleaning The Material Tube

- Repeat cleaning procedure from the nozzle end of the gun.
- When the gun and all parts are thoroughly cleaned, use turbine hose

to dry the parts and blow fun passages dry. Thorough drying before reassembly prevents coating contamination during the next operation of the unit and inhibits oxidation of internal gun components.

- Reinstall the components in reverse order of disassembly. Always install nozzle before installing the needle to prevent needle damage.
- When the gun and all parts are thoroughly cleaned, use the turbine hose to dry the parts and blow the passages dry. Thorough drying of the gun and all components prior to reassembly prevents coating contamination during the next operation of the unit, and inhibits oxidation of internal gun components.

▲ NOTICE *The four raised knobs on the air flow ring must be facing forward when assembled.*

Troubleshooting Chart

Symptom	Possible Cause(s)	Corrective Action
No material flow	<ol style="list-style-type: none"> 1. Clogged nozzle/air cap 2. Clogged cup pressure tube or fittings 3. Clogged gun 4. Clogged material tube 5. Cup seal leaking 6. Material not properly mixed or improperly filtered 	<ol style="list-style-type: none"> 1. Disassemble and clean 2. Disassemble and clean (a straight pin can be used to clean fittings) 3. Disassemble and clean 4. Disassemble and clean gun and check valve 5. Inspect cup seal, cup cap and clean or replace as necessary 6. Strain paint
Slow material flow	<ol style="list-style-type: none"> 1. Material too thick 2. Improper material adjustment 3. Wrong needle/nozzle 4. Air filter clogged 5. Material not properly mixed or improperly filtered 6. Material too cold 	<ol style="list-style-type: none"> 1. Clean material tube, gun and fittings then thin the material 2. Adjust material control knob 3. Refer to material application chart for correct needle/nozzle 4. Remove and replace air filter 5. Strain paint 6. Raise material temp. to 60°F (15°C)
Material leak	<ol style="list-style-type: none"> 1. Cup or gun damaged 2. Loose packing 3. Worn or damaged packing 4. Worn or damaged cup seal 5. Loose cup fittings 6. Loose nozzle 7. Wrong needle/nozzle assembly 8. Damaged needle 9. Loose material control knob 10. Cup seal leaking 	<ol style="list-style-type: none"> 1. Check cup gun and replace damaged parts 2. Adjust packing nut 3. Remove and replace 4. Remove and replace 5. Tighten 6. Tighten 7. Refer to material application chart for correct needle/nozzle 8. Replace 9. Properly adjust by turning clockwise 10. Clean and dry before use
Spray will not shut off	<ol style="list-style-type: none"> 1. Dirty needle 2. Packing too tight 3. Loose material control knob 	<ol style="list-style-type: none"> 1. Clean or replace needle 2. Adjust packing nut 3. Tighten
Pulsating spray	<ol style="list-style-type: none"> 1. Cup seal or check valve leaking 2. Packing improperly adjusted 3. Loose fittings on cup or gun 4. Loose retaining ring 5. Loose nozzle 6. Damaged air flow ring 7. Material not properly mixed or improperly filtered 	<ol style="list-style-type: none"> 1. Disassemble and clean 2. Adjust packing nut or replace packing 3. Tighten 4. Tighten 5. Tighten 6. Replace 7. Strain paint
Excessive overspray	<ol style="list-style-type: none"> 1. Material too thin 2. Excessive air flow 3. Wrong needle/nozzle 4. Gun too far from work surface 5. Spray blown by wind 6. Excessive material flow 7. Material not properly mixed or improperly filtered 	<ol style="list-style-type: none"> 1. Check material viscosity (add non-thinned material) 2. Adjust air flow 3. Wrong needle/nozzle assembly 4. Move gun closer to surface 5. Shelter area 6. Adjust material flow control knob 7. Strain paint

Troubleshooting Chart

Symptom	Possible Cause(s)	Corrective Action
Spray not uniform (spitting)	<ol style="list-style-type: none"> 1. Material too thick 2. Wrong needle/nozzle assembly 3. Cup seal leaking 4. Loose packing 5. Material not properly mixed or improperly filtered 	<ol style="list-style-type: none"> 1. Check material viscosity (Thin per instructions) 2. Change to proper needle/nozzle 3. Tighten cup, replace seal or check valve 4. Adjust or replace packing 5. Strain paint
Poor pattern	<ol style="list-style-type: none"> 1. Material buildup on nozzle or air cap 2. Worn nozzle/needle 3. Clogged air cap 4. Material not properly mixed or improperly filtered 	<ol style="list-style-type: none"> 1. Clean nozzle and air cap 2. Replace 3. Clean 4. Strain paint
Overheating	Clogged filter	Replace
Poor air flow	<ol style="list-style-type: none"> 1. Clogged filter 2. Air flow control improperly adjusted 	<ol style="list-style-type: none"> 1. Replace filter 2. Adjust air flow control
Spray tip clogs	<ol style="list-style-type: none"> 1. Improper material flow adjustment 2. Cup seal leaking 3. Wrong needle/nozzle 	<ol style="list-style-type: none"> 1. Adjust material control 2. Replace cup seal 3. Change to proper needle/nozzle

Troubleshooting Chart - Finish Quality

Symptom	Possible Cause(s)	Corrective Action
Orange Peel (Rough rolling appearance similar to an actual orange peeling)	<ol style="list-style-type: none"> 1. Material drying too fast 2. Gun too far from surface 3. Material too thick 	<ol style="list-style-type: none"> 1. Use a slower solvent or add a retarding agent 2. Move gun closer to surface 3. Thin material per thinning instructions
Runs and sags	<ol style="list-style-type: none"> 1. Material too thin 2. Moving gun too slow 3. Excessive material flow 4. Gun too close to surface 	<ol style="list-style-type: none"> 1. Add material to increase thickness 2. Move gun more quickly 3. Turn material control knob clockwise to reduce flow 4. Move gun further from surface
Pin-holing and solvent pops	<ol style="list-style-type: none"> 1. Trapped solvents 2. Pigment settling 3. System contamination 	<ol style="list-style-type: none"> 1. Apply material in lighter coats allowing solvents time to evaporate 2. Possible bad material 3. Thoroughly clean all parts
Fish eye	Possible silicone contamination	1. Use solvent to clean all parts and work surfaces
Blistering	<ol style="list-style-type: none"> 1. Moisture in/on surface 2. Incompatible top coats or under-coats 	<ol style="list-style-type: none"> 1. Dry surface 2. Make sure coatings are compatible
Lumpy, coarse surface	Dirt on surface	Thoroughly clean surface
Mottled surface finish	<ol style="list-style-type: none"> 1. Too much thinner 2. Poor spray technique 	<ol style="list-style-type: none"> 1. Reduce thinner 2. Refer to "Operation" for spraying instructions

▲ NOTICE

- Weather conditions can cause unsatisfactory results when spraying some coatings.
- High humidity prolongs set, and cure times.
- High temperatures decrease set, and cure times.
- Cold temperatures extend set, and cure times.
- Variations in temperature, and humidity can cause variations in finish quality.
- Coating manufacturers can recommend additives to resolve some of these problems, and should be contacted for assistance with particular problem resolutions.

For Replacement Parts, Call 1-800-626-4401

Please provide following information:

- Model number
- Serial number (if any)
- Part description and number as shown in parts list

Address parts correspondence to:

Campbell Hausfeld
Attn: Parts Department
100 Production Drive
Harrison, OH 45030 U.S.A.

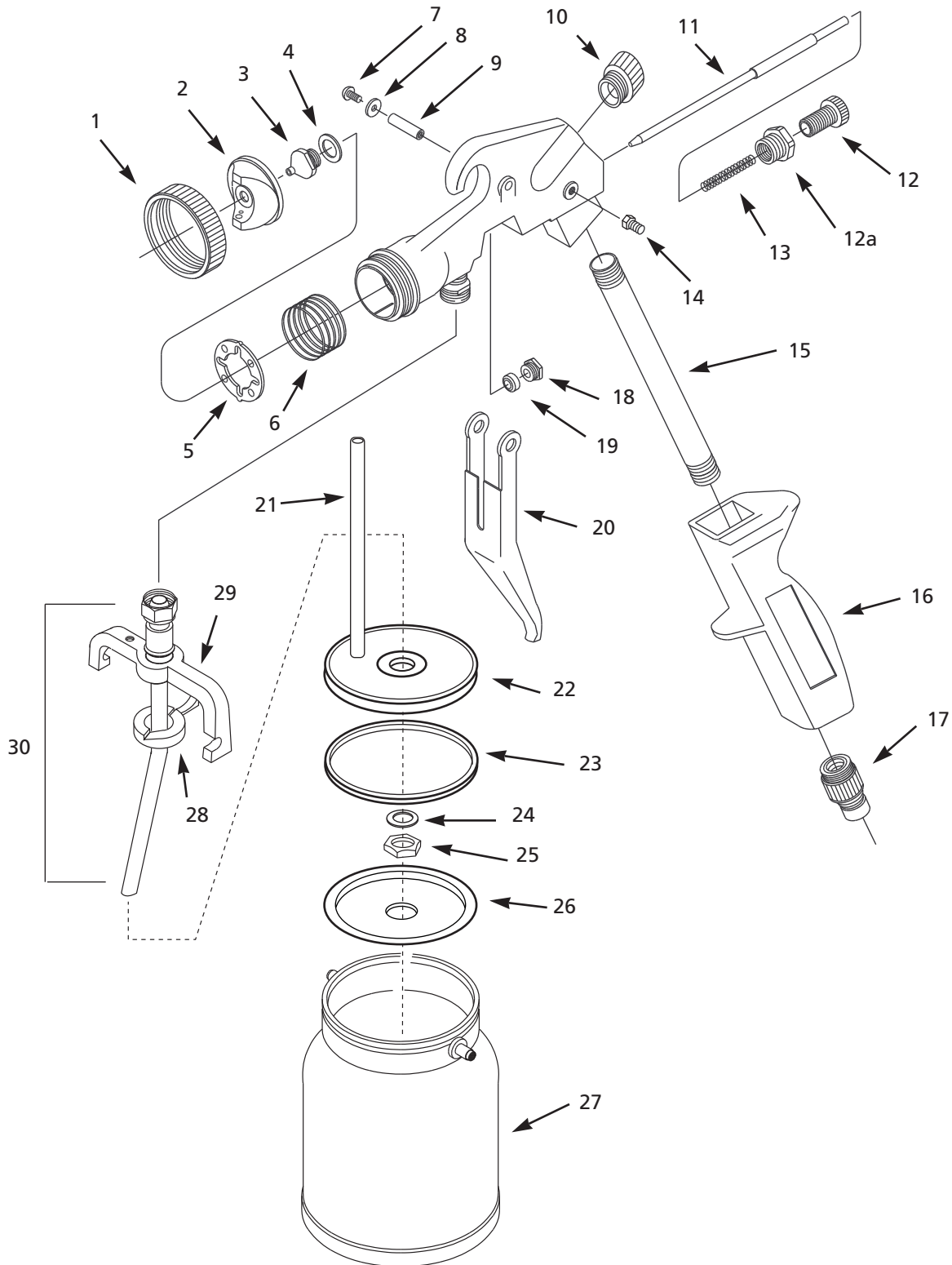

Replacement Parts List

Ref No.	Description	Part Number	Qty
1	Retaining Ring	HV104504AV	1
2	Aircap	HV104505AV	1
3	1.00 mm Needle/Nozzle Set	HV104521SV	1
4	Nozzle Gasket	HV104524AV	1
5	Air Flow Ring	HV104511AV	1
6	Aircap Spring	HV104512AV	1
7	Trigger Pin Kit (incl. #7 (2) & #9 (1))	HV104509AV	1
8	Trigger Washer	HV104508AV	2
9	Trigger Pin	Incl. in #7	
10	Port Plug	HV104001AV	1
11	1.00 mm Needle	Incl. in #3	
12	Material Adjustment Knob	HV104502AV	1
12a	Adjuster Insert	HV104503AV	1
13	Needle Spring	HV104513AV	1
14	Pressure Tube Fitting	HV004700AV	2
15	Handle Tube	HV104501AV	1
16	Handle	HV103800AV	1
17	Quick Connect Fitting	HV103901AV	1

Ref No.	Description	Part Number	Qty
18	Packing Nut	HV104515AV	1
19	Packing	HV104514AV	1
20	Trigger	HV104507AV	1
21	Pressure Tube	HV006201AV	1
22	Canister Lid	DH962100AV	1
23	Canister Seal	SK206401AJ	3
24	Nylon Washer	ST077903AV	1
25	Canister Nut	DH077800AV	1
26	Check Valve	HV004400AV	1
27	Canister	DH077900AV	1
28	Lever	DH962400AV	1
29	Yoke Assembly	DH962300AV	1
30	Material Tube Assembly	DH077300AV	1
	Wrench	HV104525SV	1
	Canister Assembly (incl. #22 - #30)	SK205800AJ	1
	Pressure Tube Fitting Kit (incl. #14 & #21)	SK105100AJ	1
	Air Flow Control Assembly	HV011301SV	1
	.75 mm Needle/Nozzle Set	HV104520SV	1

Limited Warranty

1. DURATION: From the date of purchase by the original purchaser as follows: Standard Duty Paint Application Systems and all Paint Application Accessories - 1 year, Serious Duty Paint Application Systems - 3 years, Extreme Duty Paint Application Systems - 5 years.
2. WHO GIVES THIS WARRANTY (WARRANTOR): Campbell Hausfeld/A Scott Fetzer Company, 100 Production Drive, Harrison, Ohio, 45030, Telephone: 1-800-626-4401.
3. WHO RECEIVES THIS WARRANTY (PURCHASER): The original purchaser (other than for purposes of resale or rental) of the Campbell Hausfeld Product.
4. WHAT PRODUCTS ARE COVERED BY THIS WARRANTY: All non-compressor driven paint application systems, HVLP spraying systems, and paint application accessories supplied or manufactured by the Warrantor.
5. WHAT IS COVERED UNDER THIS WARRANTY: Defects in material and workmanship which occur within the duration of the warranty period. Warrantor will also cover normal wear items for a period of thirty days from the date of original purchase against defects in material and workmanship. These wear items are: HVLP-filters, motor brushes, gun packing, gun canister seal, gun check valve and gun air flow ring; Airless-inlet valve, outlet valve, gun valve, filters, tips, all seals and o-rings.
6. WHAT IS NOT COVERED UNDER THIS WARRANTY:
 - A. Implied warranties, including those of merchantability and FITNESS FOR A PARTICULAR PURPOSE ARE LIMITED FROM THE DATE OF ORIGINAL PURCHASE AS STATED IN THE DURATION. If standard duty product is used for commercial or industrial purposes, the warranty will apply for ninety (90) days from the date of original purchase. If product is used for rental purposes, the warranty will apply for ninety (90) days from the date of original purchase. Some states do not allow limitation on how long an implied warranty lasts, so the above limitations may not apply to you.
 - B. ANY INCIDENTAL, INDIRECT, OR CONSEQUENTIAL LOSS, DAMAGE, OR EXPENSE THAT MAY RESULT FROM ANY DEFECT, FAILURE, OR MALFUNCTION OF THE CAMPBELL HAUSFELD PRODUCT. Some states do not allow the exclusion or limitation of incidental or consequential damages, so the above limitation or exclusion may not apply to you.
 - C. Any failure that results from an accident, purchaser's abuse, neglect or failure to operate products in accordance with instructions provided in the owner's manual(s) supplied with product. Accident, purchaser's abuse, neglect or failure to operate products in accordance with instructions shall also include the removal or alteration of any safety devices. If such safety devices are removed or altered, this warranty is void.
 - D. Normal adjustments which are explained in the owner's manual(s) provided with the product.
 - E. Items or services that are normally required to maintain the product: HVLP-filters, motor brushes, gun packing, gun canister seal, gun check valve and gun air flow ring; Airless-inlet valve, outlet valve, gun valve, filters, tips, all seals and o-rings., or any other expendable part not specifically listed, will only be covered for thirty days from date of original purchase.
7. RESPONSIBILITIES OF WARRANTOR UNDER THIS WARRANTY: Repair or replace, at Warrantor's option, products or components which are defective, have malfunctioned and/or failed to conform within duration of the warranty period.
8. RESPONSIBILITIES OF PURCHASER UNDER THIS WARRANTY:
 - A. Provide dated proof of purchase and maintenance records.
 - B. Deliver or ship the Campbell Hausfeld product or component to the nearest Campbell Hausfeld Authorized Service Center. Freight costs, if any, must be borne by the purchaser.
 - C. Use reasonable care in the operation and maintenance of the products as described in the owner's manual(s).
9. WHEN WARRANTOR WILL PERFORM REPAIR OR REPLACEMENT UNDER THIS WARRANTY:
 - A. Repair or replacement will be scheduled and serviced according to the normal work flow at the servicing location, and depending on the availability of replacement parts.
 - B. If the purchaser does not receive satisfactory results from the Authorized Service Center, the purchaser should contact Campbell Hausfeld (see paragraph 2)

This Limited Warranty applies in the U.S. and Canada only and gives you specific legal rights. You may also have other rights which vary from state to state, or country to country.