

Power Pack



GR3000, GR3100, GR3500

Table of Contents

Description 1
 Unpacking 1
 Safety Guidelines 2
 Safety Symbols 2
 Important Safety Information 2 - 5
 Glossary of Terms 6
 Pre-operation 7 - 8
 Generator Operation 8 - 9
 Welder Operation 10
 Compressor Operation 10
 Maintenance 11 - 12
 Storage 12
 Welding Guidelines 13 - 16
 Troubleshooting Chart 16 - 18
 General 16
 Generator 17
 Welder 17
 Welds 18
 Wiring Diagram 19
 Warranty 20

Description

Power Pack is a mobile power source that can provide solutions for jobs offsite and in remote powerless locations. It can be used as a generator, welder, or air compressor. Powered by an air-cooled four cycle engine, this machine is designed to run at maximum RPM. The Power Pack offers protection features such as; low-oil level shutoff which provides protection for the engine; and a thermostatically protected alternator. The welding system is designed to weld in the Stick process (SMAW). The 140 amp AC stick welder can weld up to 5/16 inch steel. The air compressor provides compressed air to power pneumatic tools and operate spray guns. The pump is oil lubricated; therefore a small amount of oil carryover is present in the compressed air stream. NOTE: Applications requiring air free of oil or water should have the appropriate coalescing filter installed.

Unpacking

After unpacking the unit, inspect carefully for any damage that may have occurred during transit. Make sure to tighten fittings, bolts, etc., before putting unit into service. Report any missing items by calling 1-800-746-5641.

▲ WARNING

Do not operate unit if damaged during shipping, handling or use. Damage could result in bursting and cause injury or property damage.

▲ DANGER

Breathable Air Warning

This product is neither designed, nor approved by the National Institute for Occupational Safety and Health (NIOSH), for use as a supplied air system.

RETAIN THIS INFORMATION FOR FUTURE REFERENCE

Serial Number:

Model Number:

Date of Purchase:

Safety Guidelines

This manual contains information that is very important to know and understand. This information is provided for SAFETY and to PREVENT EQUIPMENT PROBLEMS. To help recognize this information, observe the following symbols.

⚠ DANGER Danger indicates an imminently hazardous situation which, if not avoided, WILL result in death or serious injury.

⚠ WARNING Warning indicates a potentially hazardous situation which, if not avoided, COULD result in death or serious injury.

⚠ CAUTION Caution indicates a potentially hazardous situation which, if not avoided, MAY result in minor or moderate injury.

NOTICE Notice indicates important information, that if not followed, may cause damage to equipment.

IMPORTANT: Information that requires special attention.

Safety Symbols

The following Safety Symbols appear throughout this manual to alert you to important safety hazards and precautions.



Wear Eye and Mask Protection



Read Manual First



Wear Eye and Ear Protection



Risk of Explosion



Risk of Electrocutation



Risk of Flying Fragments



Risk of Light Rays



Risk of Hot Parts



Risk of Fire



Risk of Fumes



Risk of Magnetism



Risk of Pressure

Please read and save these instructions. Read carefully before attempting to assemble, install, operate or maintain the product described. Protect yourself and others by observing all safety information. Failure to comply with instructions could result in personal injury and/or property damage! Retain instructions for future reference.

Important Safety Information

This manual contains important safety, operational and maintenance information. If you have any questions, please call 1-800-746-5641 for customer assistance.

CALIFORNIA PROPOSITION 65

⚠ WARNING This product contains and/or produces chemicals, including lead, known to the State of California to cause cancer and birth defects or other reproductive harm.



EMISSIONS

NOTICE Engines that are certified to comply with U.S. EPA emission regulations for SORE (Small Off Road Equipment), are certified to operate on regular unleaded gasoline, and may include the following emission control systems: (EM) Engine Modifications and (TWC) Three-Way Catalyst (if so equipped).

⚠ DANGER Using a generator indoors CAN KILL YOU IN MINUTES. Generator exhaust contains carbon monoxide. This is a poison you cannot see or smell.

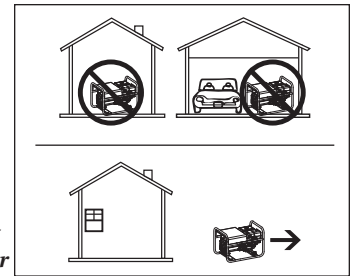

- ◆ NEVER use inside a house or garage, EVEN IF doors and windows are open.
- ◆ Only use OUTSIDE and far away from windows, doors and vents.

GENERAL SAFETY

- ◆ Before starting or servicing any unit, read and understand all instructions. Failure to follow safety precautions or instructions can cause equipment damage and or serious personal injury or death. Engine instructions for these units are contained in a separate manual. Retain all manuals for future reference.
- ◆ Wear safety glasses and use hearing protection when operating the unit.



⚠ DANGER Never operate this unit in an explosive, flammable and/or combustible atmosphere.



- ◆ Never use this unit for any application other than that specified by the manufacturer. Never operate this unit under conditions not approved by the manufacturer. Never attempt to modify this unit to perform in any manner not intended by the manufacturer.
- ◆ If the equipment should start to vibrate abnormally, STOP the engine/motor and check immediately for the cause. Vibration is generally a warning of trouble.
- ◆ For maintenance and repairs, use only products and parts recommended by the manufacturer.
- ◆ Be sure that the unit is properly grounded to an external ground path prior to operation. Refer to the section entitled "Grounding Instructions" for proper grounding procedures.
- ◆ Be sure that the unit is operated only by persons who have read and understand these instructions.
- ◆ Be sure that the unit is placed on a flat level surface prior to and during operation. The unit must not slide or shift during operation.

Important Safety Information (Continued)

- ◆ Keep all persons away from the unit during operation.
- ◆ NEVER allow children in the work area.
- ◆ Do not allow persons wearing loose clothing or jewelry to start or operate the unit. Loose clothing or jewelry may become entangled in moving components, causing equipment damage and or personal injury.
- ◆ Keep all persons away from parts that move or become hot during operation.
- ◆ Use only unleaded fuel. Do not refill the fuel tank while the engine is running. Use precautions to prevent fuel spillage during refills. Be sure the fuel tank cap is securely in place before starting the engine. Clean up any spilled fuel before starting the engine. Allow engine to cool for at least two minutes before refueling. Do not add fuel while smoking or if unit is near any sparks or open flames. Do not overfill tank - allow room for fuel to expand. Always keep nozzle in contact with tank during fueling. Never fuel the unit indoors. Failure to follow these instructions could result in death or serious injury.
- ◆ To reduce fire hazard, keep engine/motor exterior free of oil, solvent, or excessive grease.

▲ CAUTION *Never mix oil with gasoline for this engine. This is a four cycle engine designed to run on pure gasoline. Oil is used for engine lubrication purposes only.*

- ◆ All installation, maintenance, repair and operation of this equipment should be performed by qualified persons only in accordance with national, state, and local codes.
- ◆ Verify that all components of the unit are clean and in good condition prior to operation. Be sure that the insulation on all cables, electrode holders, and power cords is not damaged. Inspect compressed air system, fuel system and electrical components for signs of damage, deterioration, weakness or leakage. Always repair or replace damaged components before operating the unit. Always keep panels, shields, etc. in place when operating.
- ◆ Check all fasteners at frequent intervals for proper tightness.
- ◆ Always operate the unit in a clean, dry, well ventilated area. Do not operate the unit in humid, wet, rainy, or poorly ventilated areas.
- ◆ Always shut the equipment off prior to moving the unit.
- ◆ Do not use any part of the unit as a work surface.
- ◆ Do not tamper with governor setting on engine. Overspeeding the unit severely shortens engine life and may also be very hazardous.

▲ DANGER *Shut off the engine and disconnect the spark plug wire before performing any service or maintenance to the unit.*

GENERATOR SAFETY

- ◆ Be sure all powered devices are shut off prior to connecting them to the unit.
- ◆ Be sure that all tools and appliances are in good repair and are properly grounded. Use devices that have three prong power cords. If an extension cord is used, be sure that it has three prongs for proper grounding.
- ◆ This unit may be used for emergency stand-by service. In such cases, a manual transfer switch must be installed between the electric utilities meter and the electrical distribution box. This switch should be installed by a licensed electrician.

WELDER SAFETY

▲ WARNING *Always keep a fire extinguisher accessible while performing arc welding operations.*



▲ WARNING *Improper use of electric arc welders can cause electric shock, injury, and death! Take all precautions described in this manual to reduce the possibility of electric shock.*



- ◆ Always wear dry protective clothing and welding gloves, and insulated footwear.
- ◆ Be sure that the work piece is properly supported and grounded prior to beginning any electric arc welding operation.
- ◆ Coiled welding cable should be spread out before use to avoid overheating and damage to insulation.
- ▲ DANGER** *Never immerse the electrode or electrode holder in water. If the unit becomes wet for any reason, be absolutely certain that it is completely clean and dry prior to attempting use!*
- ◆ Always attach the work lead first.
- ◆ Verify that the work piece is securely grounded.
- ◆ Always shut off the unit when not in use and remove the electrode from the holder.
- ◆ Never allow any part of the body to touch the electrode and ground or grounded work piece at the same time.
- ◆ Awkward welding conditions and positions can be electrically hazardous. When crouching, kneeling or at elevations, be sure to insulate all conductive parts, wear appropriate protective clothing, and take precautions to prevent injury from falls.
- ◆ Never attempt to use this equipment at current settings or duty cycles higher than those specified on the equipment labels.

Important Safety Information (Continued)

- ◆ Never use an electric arc welder to thaw frozen pipes.

▲ WARNING *Flying sparks and hot metal can cause injury. As welds cool, slag can be thrown off. Take all precautions described in this manual to reduce the possibility of injury from flying sparks and hot metal.*

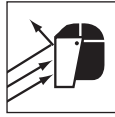

- ◆ Wear ANSI compliant face shield or safety glasses with side shield protection when chipping or grinding metal parts.
- ◆ Wear ear plugs when welding overhead to prevent spatter or slag from falling into ears.

▲ WARNING *Electric arc welding operations produce intense light and heat and ultraviolet (UV) rays. This intense light and UV rays can cause injury to eyes and skin. Take all precautions described in this manual to reduce the possibility of injury to eyes and skin.*

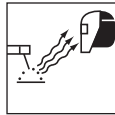

- ◆ All persons operating this equipment or in the area while equipment is in use must wear protective welding gear including: welding helmet or shield with at least shade 10, flame resistant clothing, leather welding gloves, and full foot protection.

▲ WARNING *Never look at arc welding operations without eye protection as described above. Never use a shade filter lens that is cracked, broken, or rated below number 10. Warn others in the area not to look at the arc.*

▲ WARNING *Electric arc welding operations cause sparks and heat metal to temperatures that can cause severe burns! Use protective gloves and clothing when performing any metal working operation. Take all precautions described in this manual to reduce the possibility of skin and clothing burns.*



- ◆ Make sure that all persons in the welding area are protected from heat, sparks, and ultraviolet rays. Use additional face shields and flame resistant barriers as needed.
- ◆ Never touch work pieces until completely cooled.

▲ WARNING *Heat and sparks produced during electric arc welding and other metal working operations can ignite flammable and explosive materials! Take all precautions described in this manual to reduce the possibility of flames and explosions.*



- ◆ Remove fire hazards from the welding area. If this is not possible, cover them to prevent the welding sparks from starting a fire. Welding sparks and hot materials from welding can easily go through small cracks and openings to adjacent areas. Avoid welding near hydraulic lines. Have a fire extinguisher readily available.
- ◆ Take precautions to be sure that flying sparks and heat do not cause flames in hidden areas, cracks, behind bulkheads, etc.

▲ WARNING *Fire and explosion hazard! Do not weld on containers or pipes that contained flammable/combustible materials or gases.*



▲ WARNING *Arc welding closed cylinders or containers such as tanks or drums can cause explosion if not properly vented! Verify that any cylinder or container to be welded has an adequate ventilation hole, so that expanding gases can be released.*



▲ WARNING *Do not breathe the fumes that are produced by the arc welding operation. These fumes are dangerous. If the welding area cannot be adequately ventilated, be sure to use an air-supplied respirator.*



- ◆ Keep your head out of the welding fumes.
- ◆ Do not perform electric arc welding operations on metals that are galvanized or cadmium plated, or contain zinc, mercury, or beryllium without completing the following precautions:
 - Remove the coating from the base metal.
 - Make sure that the welding area is well ventilated.
 - Use an air-supplied respirator.

Extremely toxic fumes are created when these metals are heated.

▲ WARNING *The electromagnetic field that is generated during arc welding may interfere with the operation of various electrical and electronic devices such as cardiac pacemakers. Persons using such devices should consult with their physician prior to performing any electric arc welding operations.*



- ◆ Route the electrode and work cables together and secure with tape when possible.
- ◆ Never wrap arc welder cables around the body.
- ◆ Always position the electrode and work leads so that they are on the same side of the body.
- ◆ Exposure to electromagnetic fields during welding may have other health effects which are not known.

▲ WARNING *Always be sure that the welding area is secure and free of hazards (sparks, flames, glowing metal or slag) prior to leaving. Be sure that the equipment is turned off and electrode is removed. Be sure that cables are loosely coiled and out of the way. Be sure that all metal and slag has cooled.*

Important Safety Information (Continued)

COMPRESSOR SAFETY

▲ WARNING *Never remove or attempt to adjust safety valve. Keep safety valve free from paint and other accumulations.*

▲ DANGER *Never attempt to repair or modify a tank! Welding, drilling or any other modification will weaken the tank resulting in damage from rupture or explosion. Always replace worn or damaged tanks.*



- ◆ Tanks rust from moisture build-up, which weakens the tank. Make sure to drain tank regularly and inspect periodically for unsafe conditions such as rust formation and corrosion.

NOTICE *Drain liquid from tank daily.*

- ◆ Fast moving air will stir up dust and debris which may be harmful. Release air slowly when draining moisture or depressurizing the compressor system.

SPRAYING PRECAUTIONS

▲ WARNING *Do not spray flammable materials in vicinity of open flame or near ignition sources including the compressor unit.*



- ◆ Do not smoke when spraying paint, insecticides, or other flammable substances.
- ◆ Use a face mask/respirator when spraying and spray in a well ventilated area to prevent health and fire hazards.
- ◆ Do not direct paint or other sprayed material at the compressor. Locate compressor as far away from the spraying area as possible to minimize overspray accumulation on the compressor.
- ◆ When spraying or cleaning with solvents or toxic chemicals, follow the instructions provided by the chemical manufacturer.



The **DANGER, WARNING, CAUTION, and NOTICE** notifications and instructions in this manual cannot cover all possible conditions and situations that may occur. It must be understood by the operator that caution is a factor which cannot be built into this product, but must be supplied by the operator.

SAFETY STANDARDS AND SUGGESTED READING

ANSI Standard Z49.1 from American Welding Society, 550 N.W. LeJune Rd. Miami, FL 33126

Safety and Health Standards

OSHA 29 CFR 1910, from Superintendent of Documents, U.S. Government Printing Office, Washington, D.C. 20402

National Electrical Code

NFPA Standard 70, from National Fire Protection Association, Batterymarch Park, Quincy, MA 02269

Safe Handling of Compressed Gases in Cylinders

CGA Pamphlet P-1, from Compressed Gas Association, 1235 Jefferson Davis Highway, Suite 501, Arlington, VA 22202

Code for Safety in Welding and Cutting

CSA Standard W117.2, from Canadian Standards Association, Standards Sales, 178 Rexdale Boulevard, Rexdale, Ontario, Canada M9W 1R3

Cutting And Welding Processes

NFPA Standard 51B, from National Fire Protection Association, 1 Battery March Park, P.O. Box 9146, Quincy, MA 02269-9959.

Practice For Occupational And Educational Eye And Face Protection

ANSI Standard Z87.1, from American National Standards Institute, 11 West 42nd Street, New York, NY 10036

Arc Welding and Your Health: A Handbook of Health Information for Welding

From The American Industrial Hygiene Association, 2700 Prosperity Avenue, Suite 250, Fairfax, VA 22031-4319.

Cutting and Welding Processes

NFPA Standard 51B from National Fire Protection Association, 1 Battery March Park, P.O. Box 9146, Quincy, MA 02269-9959.

OSHA Hazard Communication Standard 29 CFR 1910.1200

OSHA General Industry Standard 29 CFR 1910 Subpart Q from the Occupational Safety and Health Administration, www.osha.org or contact your local OSHA office.

Applications Manual for the Revised NIOSH Lifting Equation

From The National Institute for Occupational Safety and Health (NIOSH), 1600 Clifton Road, Atlanta, GA 30333

Refer to the Material Safety Data Sheets (MSDS) and the manufacturers' instructions for metals, electrodes, coatings and cleaners.

**SAVE THESE INSTRUCTIONS
DO NOT DISCARD**

Glossary of Terms

AC or Alternating Current - electric current that reverses direction periodically. Sixty cycle current travels in both directions sixty times per second.

Arc Length - the distance from the end of the electrode to the point where the arc makes contact with the work surface.

Base Metal - the material to be welded.

Butt Joint - a joint between two members aligned approximately in the same plane.

Crater - a pool, or pocket, that is formed as the arc comes in contact with the base metal.

DC or Direct Current - electric current which flows only in one direction. The polarity (+ or -) determines which direction the current is flowing.

DC Reverse Polarity - occurs when the electrode holder is connected to the positive pole of the welding machine. Reverse Polarity directs more heat into melting the electrode rather than the work piece. It is used on thinner material.

DC Straight Polarity - occurs when the electrode holder is connected to the negative pole of the welding machine. With straight polarity more heat is directed to the work piece for better penetration on thicker material.

Electrode - a coated metal wire having approximately the same composition as the material being welded.

Fillet Weld - approximately a triangle in cross-section, joining two surfaces at right angles to each other in a lap, T or corner joint.

Flux - a coating, when heated, that produces a shielding gas around the welding area. This gas protects the parent and filler metals from impurities in the air.

Flux Cored Arc Welding (FCAW) - also called Gasless, is a welding process used with a wire-feed welding machine. The weld wire is tubular with flux material contained inside for shielding.

Gas Metal Arc Welding (GMAW) - also called MIG, is a welding process used with a wire feed welding machine. The wire is solid and an inert gas is used for shielding.

Gas Tungsten Arc Welding (GTAW) - also called TIG, is a welding process used with welding equipment with a high frequency generator. The arc is created between a non-consumable tungsten electrode and the work piece. Filler metal may or may not be used.

Lap Joint - a joint between two overlapping members in parallel planes.

Open Circuit Voltage (OCV) - the voltage between the electrode and the work clamp of the welding machine when no current is flowing (not welding). The OCV determines how quickly the arc is struck.

Overlap - occurs when the amperage is set too low. In this instance, the molten metal falls from the electrode without actually fusing into the base metal.

Porosity - gas pockets, or cavities, formed during weld solidification. They weaken the weld.

Penetration - the depth into the work piece that has been heat effected by the arc during the welding process. A good weld achieves 100% penetration meaning that the entire thickness of the work piece has been heated and resolidified. The heat effected area should be easily seen on the opposite side of the weld.

Shielded Metal Arc Welding (SMAW) - also called Stick, is a welding process that uses a consumable electrode to support the arc. Shielding is achieved by the melting of the flux coating on the electrode.

Slag - a layer of flux soot that protects the weld from oxides and other contaminants while the weld is solidifying (cooling). Slag should be removed after weld has cooled.

Spatter - metal particles thrown from the weld which cool and harden on the work surface. Spatter can be minimized by using a spatter resistant spray on the work piece before welding.

Tack Weld - weld made to hold parts in proper alignment until final welds are made.

Travel Angle - the angle of the electrode in the line of welding. It varies from 5° to 45° depending on welding conditions.

T Joint - made by placing the edge of one piece of metal on the surface of the other piece at approximately a 90° angle.

Undercut - a condition that results when welding amperage is too high. The excessive amperage leaves a groove in the base metal along both sides of the bead which reduces the strength of the weld.

Weld Pool or Puddle - a volume of molten metal in a weld prior to its solidification as weld metal.

Weld Bead - a narrow layer or layers of metal deposited on the base metal as the electrode melts. Weld bead width is typically twice the diameter of the electrode.

Work Angle - the angle of the electrode from horizontal, measured at right angles to the line of welding.

Pre-Operation

LOCATION

Selecting the proper location can significantly increase performance, reliability and life of the unit.

- ◆ For best results locate the unit in an environment that is clean and dry. Dust and dirt in the unit retain moisture and increase wear of moving parts.
- ◆ There are mounting holes in the bottom of the open frame models to permanently mount the unit if desired. The bolt pattern is 20 inch x 26 inch and will accept 1/2 inch bolts. The wheels (if present) must be removed.
- ◆ Store electrodes in a clean, dry location with low humidity to preserve the flux coating.

LUBRICATION

NOTICE

CHECK ENGINE AND PUMP OIL LEVELS BEFORE OPERATING! Follow lubrication

instructions before operating compressor.

1. Oil is NOT mixed with the gasoline, however adequate oil supply is necessary for proper engine lubrication. Refer to the Engine Manual for SAE, API and fill quantity specifications.
2. Remove pump breather and fill pump with 8.5 oz. of oil. Use full synthetic motor oil like Mobil 1® 10W-30. Do not use regular automotive oil such as 10W-30. Additives in regular oil can cause valve deposits and reduce pump life. For pumps with an oil sight glass, oil level can be monitored and maintained as shown in Figure 1.

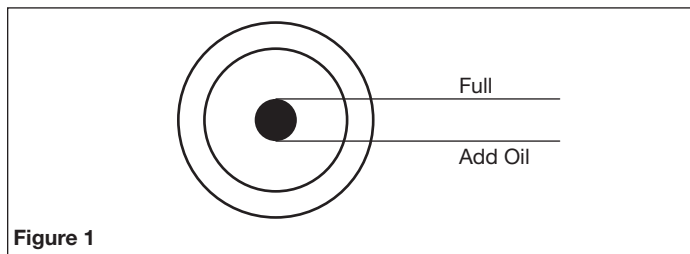

Figure 1

GROUNDING

1. Use the ground terminal and wing nut on the frame to connect the unit to a suitable ground source. Securely fasten the end terminal of the ground wire to the ground terminal on the frame. Tighten the washer and wing nut on top of the ground wire end terminal.
2. The ground wire should be made of #8 gauge wire. Do not use wire with a higher gauge number. Higher gauge numbers indicate thinner wire, which may not provide an adequate ground path.
3. The other end of the ground wire must be securely fastened to an approved ground source.

The following are ground sources approved by the National Electric Code. Other ground sources may be acceptable. Refer to the National Electric Code and local regulations for further ground source information. If not sure of regulations

or procedures, obtain assistance from a qualified (licensed or certified) electrical technician.

- a. An underground water pipe at least ten feet in length
- b. A non-corrosive underground pipe at least eight feet in length and 3/4 inch diameter
- c. A steel or iron underground rod at least eight feet in length and 5/8 inch diameter
- d. A non-ferrous rod at least eight feet in length, 1/2 inch in diameter, and approved for grounding purposes

Any rod or pipe used for grounding must be driven to eight feet deep or buried in the deepest possible trench.

STARTING

1. Remove all electrical loads from the unit.
2. Set compressor switch to OFF position.
3. Move fuel shut-off lever as far as possible to the right to enable fuel flow.
4. Set the engine switch to the RUN position.
5. For a cool engine, pull the choke knob out.
6. Push and hold the START switch until the engine starts, then release.
7. After each start up, allow the engine to run for 2 to 3 minutes with no load.
8. As the engine warms up and stabilizes, adjust the choke knob in fully.

CAUTION

Engine speed is preset to provide proper output voltage. Never attempt to modify or adjust engine speed or output voltage.

ENGINE BREAK-IN

After initial start-up, the engine should be broken in according to the manufacturer's instructions. Refer to the engine manual for the proper break-in procedure.

COMPRESSOR BREAK-IN

Open the drain valves in the end of the two tanks. Turn the compressor switch to ON and allow the pump to run without a load for 30 minutes. After 30 minutes, close the drain petcocks and pressure will begin to build in the tanks.

SHUT-OFF

1. Shut off and remove all electrical load devices from the unit
2. Set compressor switch to OFF position.
3. Allow the engine to run for 2-3 minutes with no electrical loads.
4. Set the engine switch to the OFF position.
5. Verify that the unit has completely stopped.
6. Close the fuel supply valve.
7. Allow the unit to cool before installing any covers or storing unit.

Pre-Operation (Continued)

LOW OIL SHUTDOWN

A low oil shutdown switch is provided to protect the engine. When engine oil level drops too low for proper engine operation, the low oil shutdown switch causes the engine to shut off. If oil level is low when attempting to start the engine, the low oil level shutdown switch prevents the engine from starting. If engine does not start, check oil level.

NOTE: It is important to keep the unit on a level surface. The oil level shutdown switch can prevent the engine from starting even if oil level is sufficient, when the unit is placed on an uneven surface.

Generator Operation

(FRONT PANEL SWITCHES MUST BE SET TO GENERATOR AND 120V/240V POSITIONS)

1. All load devices and extension cords should use three prong terminals. Refer to Table 2 for extension cord and cable size requirements.
2. Allow the engine to run for 2-3 minutes before applying any electrical loads.
3. The 120 volt duplex receptacles are rated for 20 amps and may be used in any combination of 120 volt loads and also with 240 volt loads through the 240 volt receptacles.

These duplex receptacles are of the Ground Fault Circuit Interrupter (GFCI) type. Ground Fault Circuit Interrupters can significantly reduce the possibility of injury if an electrical short occurs. The engine must be running and the front panel switches set to supply power to the receptacles before the GFCI's can be reset.

▲ WARNING *A Ground Fault Circuit Interrupter may not be effective if the unit is not grounded! Refer to the section entitled Grounding for proper steps to ground the unit.*

The 120/240 volt twist lock receptacle is rated for 30 amps and may be used in any combination of 120 volt and 240 volt loads.

4. Individual receptacles should not be loaded beyond the amperage rating.
5. Total combined load through any combination of receptacles must not exceed the rated load limits of the unit. Refer to the identification plate on the unit for amp and wattage specifications.
6. Always shut off and remove loads before starting or shutting off the engine.
7. When plugging multiple electrical load devices into the receptacles, be sure to connect and activate the highest power draw item first. Allow the engine to stabilize, then connect and activate the next highest power draw device. The smallest power draw device should be connected to the receptacle and activated last.

NOTE: Power draw can be calculated by multiplying volts and amps. The resulting number is wattage.

Never exceed the posted maximum wattage for the unit or any individual receptacle. Refer to owner's manuals and product tags to determine the wattage of all electrical load devices.

If actual watt ratings are not available, the Power Usage Chart, see Table 1, may be used as a general guideline.

Remember that devices which generate heat during operation such as heaters, incandescent light bulbs, motors and hair dryers have a higher power draw than devices which generate little heat during operation such as florescent bulbs, radios, and clocks.

Long power cords and extension cords also draw additional power. Keep cords at minimum possible length.

Refer to Table 2 for maximum limits for lengths of extension cords.

8. Circuit protection is provided by circuit breakers. The main circuit breaker is a rocker type rated for 30 amps. This is the maximum total current draw for all receptacles in combination. A 20 amp circuit breaker supplies each of the two duplex receptacles. The circuit breaker opens when the load exceeds its maximum capacity or a short circuit occurs. If the circuit breaker opens, perform the following procedures to correct the problem:
 - a. Shut off and disconnect all electrical loads.
 - b. Attempt to determine the cause of the electrical problem - overloading or short circuit.
 - c. Do not use any devices that have short circuits. Avoid overloading the unit.
 - d. Press the circuit breaker pushbutton or rocker to reset the circuit breaker.

▲ CAUTION *Repeated cycling of the circuit breaker indicates a problem and may cause damage to the unit or load devices. Do not operate the unit if repeated cycling of the circuit breaker occurs.*

Generator Operation (Continued)

INSTALLATION FOR STAND-BY USE

Precautions must be taken to prevent electrical back feeding into utility systems. This requires isolation of the electrical system. To isolate the electrical system, perform the following procedures:

1. Turn off the main electrical system switch prior to connecting the unit.
2. In accordance with national and local standards, a double throw transfer switch must be installed in the system.



WARNING

Always shut off main power prior to temporary connection of the unit to a building electrical system.



WARNING

Installation of the unit as a backup electrical source must be performed by a qualified (licensed or certified) electrical technician.

TABLE 1 - ESTIMATED POWER USAGE (WATTS)

LOAD DEVICE	WATTS	LOAD DEVICE	WATTS	LOAD DEVICE	WATTS	LOAD DEVICE	WATTS
Bench grinder (8 in)	1400-2500	Electric fry pan	1500	Radio	50-200	Window air conditioner	1500-2200
Coffee maker	400-700	Fan	40-200	Refrigerator or freezer	130-1200	Microwave oven	1000-1500
Electric drill (3/8 inch, 4 amps)	440-600	Circular saw (Heavy duty 7-1/4 inch)	1400-2300	Sump pump	800-2200	Water pump	1000-3000
Electric drill (1/2 inch, 5.4 amps)	600-900	Table saw (10 inch)	1800-4500	Television	200-500	Water heater	1000-5000
				Light bulb	AS RATED	Space heater	600-4800

TABLE 2 - EXTENSION CORDS

Maximum Recommended Lengths (in feet)

Amps	Watts 120 V	Watts 240 V	#8 Wire	#10 Wire	#12 Wire	#14 Wire	#16 Wire
2.5	300	600		1000	600	375	250
5	600	1200		500	300	200	125
7.5	900	1800		350	200	125	100
10	1200	2400		250	150	100	50
15	1800	3600		150	100	65	
20	2400	4800	175	125	75	50	
25	3000	6000	150	100	60		
30	3600	7200	125	65			
40	4800	9600	90				

TABLE 3 - WELDING CABLES

Total Cable Length *	0 - 20 feet (0 - 6 m)	20 - 40 feet (6 - 12 m)	40 - 60 feet (12 - 18 m)
Maximum Welding Current	Recommended Sizes of Copper Welding Cables		
100 A	6 AWG (16 mm ²)	6 AWG (16 mm ²)	4 AWG (25 mm ²)
150 A	6 AWG (16 mm ²)	4 AWG (25 mm ²)	2 AWG (35 mm ²)
200 A	6 AWG (16 mm ²)	4 AWG (25 mm ²)	2 AWG (35 mm ²)
250 A	6 AWG (16 mm ²)	2 AWG (35 mm ²)	1 AWG (50 mm ²)

* Total cable length is the sum of the ground and electrode cable lengths.

Welder Operation

(FRONT PANEL SWITCH MUST BE SET TO WELDER POSITION)

WELDING LEAD ASSEMBLIES

Welding leads assemblies are not included with all units. Use copper welding cables in the size specified in Table 3.

1. Verify that the surfaces of metals to be joined are free from dirt, rust, paint, oil, scale or other contaminants. These contaminants make welding difficult and cause poor welds.

▲ WARNING *All persons operating this equipment or in the area while equipment is in use must wear protective welding gear including: eye protection with proper shade (minimum shade 10), flame resistant clothing, leather welding gloves, and full foot protection.*

▲ WARNING *If heating, welding, or cutting materials that are galvanized, zinc plated, lead, or cadmium plated refer to the General Safety Information Section for instructions. Toxic fumes may be created when these materials are heated.*

2. Connect the work clamp to the work piece. Make sure the contact is on bare metal and not obstructed by paint, varnish, corrosion, or non-metallic materials.
3. Insert the exposed part of the electrode (the end with no flux) into the jaws of the electrode holder.

4. Set the amperage adjustment knob to the proper amperage for the electrode diameter. Refer to the electrode manufacturer for proper current settings.

▲ WARNING *The electrode holder and rod are electrically "live" (current potential) when the engine is running.*

5. Position the electrode to begin weld, lower the welding helmet or position the hand shield, and strike an arc. Adjust weld amperage as needed.
6. When finished welding, turn engine off and store unit properly.

DUTY CYCLE / THERMOSTATIC PROTECTION

Welder duty cycle is the percentage of actual weld time that can occur in a ten minute interval. For example, at a 10% duty cycle, actual welding can occur for one minute, then the welder must cool for nine minutes.

Internal components of the alternator are protected from overheating with an automatic thermal switch.

Compressor Operation

NOTICE *Before starting the compressor, thoroughly read all component instructions manuals, especially the engine manual.*

1. Set compressor switch to ON. The compressor clutch will engage and the pressure switch will disengage the clutch when the tank pressure reaches the preset maximum pressure. As air is discharged from the tanks and the tank pressure falls to the preset minimum pressure, the pressure switch will engage the clutch again.
2. Adjust the regulator knob to vary the outlet pressure according to the requirements of the tool(s) being used.
3. Connect air hose(s) to outlet connector(s) and connect tool(s) to hose(s).
4. An ASME safety valve in the manifold will automatically release air if the tank pressure exceeds the preset maximum.
5. The discharge tube carries compressed air from the pump to the check valve. This tube becomes very hot during use. To avoid the risk of severe burns, never touch the discharge tube.
6. The check valve allows air to enter the tanks, but prevent air in the tanks from flowing back into the compressor pump.
7. There is a drain valve in the end of each tank. They have weighted tubes to draw air/liquid from the bottom of the tanks. Use these valves to drain moisture from the tanks daily to reduce the risk of corrosion. Reduce tanks pressure below 10 PSI, then drain the moisture from the tanks daily to avoid tank corrosion.

NOTICE *Drain liquid from tank daily.*

8. All lubricated compressor pumps discharge some condensed water and oil with the compressed air. Install appropriate water / oil removal equipment and controls as necessary for the intended application.

NOTICE *Failure to install appropriate water/oil removal equipment may result in damage to machinery or workpiece.*

▲ CAUTION *Do not attach air tools to open end of the hose until startup is complete and the unit checks okay.*

MOISTURE IN COMPRESSED AIR

Moisture in compressed air will form into droplets as it comes from an air compressor pump. When humidity is high or when a compressor is in continuous use for an extended period of time, this moisture will collect in the tank. When using a paint spray or sandblast gun, this water will be carried from the tank through the hose, and out of the gun as droplets mixed with the spray material.

IMPORTANT: This condensation will cause water spots in a paint job, especially when spraying other than water based paints. If sandblasting, it will cause the sand to cake and clog the gun, rendering it ineffective.

A filter or air dryer in the air line, located as near to the gun as possible, will help eliminate moisture.

Maintenance

⚠ WARNING *Release all pressure from the system before attempting to install, service, relocate or perform any maintenance.*



In order to maintain efficient operation of the compressor system, check the air filter, oil level and gasoline level before each use. The ASME safety valve should also be checked daily. Pull ring on safety valve and allow the ring to snap back to normal position. This valve automatically releases air if the tank pressure exceeds the preset maximum. If air leaks after the ring has been released, or the valve is stuck and cannot be actuated by the ring, the ASME safety valve must be replaced.

⚠ DANGER *Do not attempt to tamper with the ASME safety valve.*

With engine OFF, clean debris from engine, flywheel, tank, air lines and pump cooling fins.

TANK

⚠ DANGER *Never attempt to repair or modify a tank! Welding, drilling or any other modification will weaken the tank resulting in damage from rupture or explosion. Always replace worn, cracked or damaged tanks.*



NOTICE *Drain liquid from tank daily.*

The tank should be carefully inspected at a minimum of once a year. Look for cracks forming near the welds. If a crack is detected, remove pressure from tank immediately and replace.

PUMP DRIVE BELT

Belt stretch is a result of normal use. When properly adjusted, the belt deflects about 1/2 inch with five pounds of force applied midway between the engine pulley and pump pulley.

To adjust pump belt tension:

1. Remove belt guards.
2. Loosen the four fasteners holding the pump to the baseplate.
3. Shift the pump in the proper direction. The belt must be properly aligned when adjustment is made.
4. To align belt, lay a straight edge against the face of the pump pulley, touching the rim at two places.

5. Adjust engine pulley so that the belt runs parallel to the straight edge. The engine pulley is attached to the crankshaft with two setscrews.
6. Tighten four fasteners holding the pump to the baseplate.
7. Recheck tension and alignment. If correct, reinstall belt guards.

ALTERNATOR DRIVE BELT

The alternator uses a synchronous drive belt transmitting a significant amount of power. Belt tension is critical to belt life. New synchronous belts will stretch after installation and use. When properly adjusted, the new belt deflects 1/10 inch with 4.5 to 4.9 pounds of force applied midway between the engine pulley and the alternator pulley. For reinstalling a used belt, the correct force to apply is 3.3 to 3.7 pounds for the same 1/10 inch deflection.

To adjust alternator belt tension:

1. Remove belt guard.
2. Loosen 2 pivot bolts and clamp bolt in alternator base plate.
3. Adjust tension nut in alternator base plate to obtain the proper tension. The belt must be properly aligned when the adjustment is made.
4. To align belt, lay a straight edge against the face of the alternator pulley, touching the rim at two places. The straight edge should be parallel with the belt.
5. Adjust alternator or engine pulley so that the belt runs parallel to the straight edge.
6. The synchronous pulleys are attached to the shafts using tapered bushings. The two set-screws must be removed and one reinserted into the hole with threads on the inner half. Tighten this screw to press the pulley and bushing apart.
7. Once the bushing is moved to the correct position, move the two set-screws back to their original locations in the holes with threads on the outer half and tighten to 175 in-lbs.
8. Tighten 2 pivot bolts and clamp bolt in alternator base plate.
9. Recheck tension and alignment. If correct, reinstall belt guard.

MAINTENANCE SCHEDULE				
OPERATION	DAILY	WEEKLY	MONTHLY	3 MONTHS
Check Oil Level	●			
Drain Tank	●			
Check Air Filter		●		
Check Safety Valve		●		
Check Belt Tightness			●	
Change Oil				●

Maintenance (Continued)

INFREQUENT USAGE

If the unit is used infrequently, starting difficulty may occur. To help prevent this, the engine should be run for approximately 30 minutes per week.

STORAGE

If the unit is not to be used for extended periods of time, the following pre-storage procedures should be performed:

1. Make sure engine oil is filled to the proper level.
2. Drain moisture from air tanks.
3. Drain all fuel from the tank, lines, carburetor and fuel valve.
4. Remove the spark plug, and pour approximately one teaspoon of oil into the spark plug hole.
5. Pull the starter cord several times to spread the oil throughout the cylinder.
6. Slowly pull the starter cord, until resistance is felt. This indicates that the piston is moving upward on the compression cycle, and the intake and exhaust valves are closed. (The piston pushes a small amount of air from the spark plug hole on compression.)
7. Use of fuel stabilizers or anti-gumming agents in the fuel system can help prevent the build up of gum and varnish.

Whenever the unit is stored, be sure that the fuel shut-off valve is in the closed position.

Refer to the engine manual that accompanies this unit for instructions regarding maintenance of engine components.

▲ WARNING *Never tamper with engine speed settings or frequency settings. Any governor adjustments should be made by qualified personnel only.*

WELD CABLES

1. Check condition of weld cables and immediately repair or replace any cables with damaged insulation.
2. Check condition of electrode holder insulating pieces and immediately replace cracked or missing parts.

EVERY 3 MONTHS

Replace any unreadable labels on the welder. Use compressed air to blow all dust and lint from the ventilation openings.

Welding Guidelines

GENERAL

This line of welding machines utilizes a process known as Shielded Metal-Arc Welding (SMAW). This process is used to bond metals by heating them with an electric arc created between the electrode and the work piece.

Electrodes used for shielded metal arc welding have two parts. The inner core is a metal rod or wire that should be similar in composition to the base metal. The outer coating is called flux. Various types of flux exist. Each coating is used for a particular welding situation.

While the metal is molten, it can be contaminated by elements in the air. This contamination could weaken the weld. The flux coating creates a protective barrier called slag that protects the molten metal from contaminants.

When current (amperage) flows through the circuit to the electrode, an arc is formed between the end of the electrode and the work piece. The arc melts the electrode and the work piece. The melted metal of the electrode flows into the molten crater and forms a bond with the work piece as shown in Figure 2.

NOTE: Discontinue using and discard electrodes that burn down to 1 to 2 inches from the electrode holder.

STRIKING AN ARC

Place the bare end of the electrode in the holder. Grip the holder lightly to reduce tiring of the hand and arm.

NOTE: Always keep the jaws of the holder clean to insure good electrical contact with the electrode.

⚠ WARNING *Be careful not to touch the work piece or welding bench with the electrode as this causes arc flashes.*

The best method of striking an arc is the scratching method. Drag the electrode at an angle along the surface much like striking a match. Upon contact with the plate, lift the electrode approximately 1/16 inch off the surface or it will stick (See Figure 3).

NOTE: Should the electrode stick to the work piece, break it loose by quickly twisting or bending at the holder while pulling upward. If the electrode does not break loose, disengage the electrode by releasing it from the holder.

ELECTRODE TYPE AND SIZE

Four types of electrodes are recommended for this welder. The electrodes are commonly known by the AWS (American Welding Society) designation as follows:

1. **E-6011 Deep penetrating**
 - Flat bead with deep penetrating arc.
 - For rusted or dirty mild steel general repair work.
2. **E-6013 General Purpose**
 - All position, smooth deposit rod with low spatter.
 - For all mild steel and general purpose work.
3. **E-7014 Fast fill**
 - Smooth bead and fast deposition
 - Ideal for joints with poor fitup and general repair work.
4. **E-7018-AC High Strength**
 - Ideal for pipes and structural applications.
 - Low hydrogen reduces porosity for a strong weld.

NOTE: Only the E-7018-AC electrode is recommended for use with these welders. Other E-7018 electrodes are designed for use with higher open circuit voltages than these welders are capable of producing. Recommended electrode diameter is 3/32 inch or 1/8 inch.

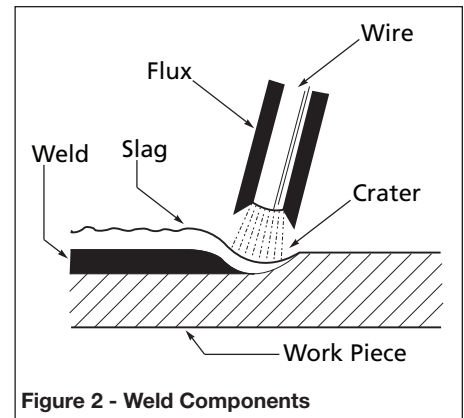

Figure 2 - Weld Components

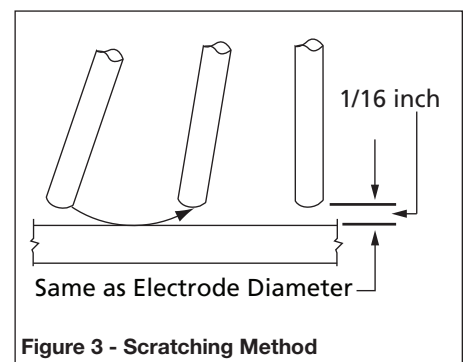

Figure 3 - Scratching Method

Welding Guidelines (Continued)

ARC WELDING BASICS

Four basic techniques affect weld quality. These are: amperage setting, weld angle, arc length, and travel speed. Proper use of these techniques is necessary for good weld quality.

AMPERAGE SETTING

The correct amperage involves the adjustment of the welding machine to the required amp setting. This is regulated by a knob on the welder. The amperage required depends on the size (diameter) of electrode used and the thickness of the work piece. Consult specifications listed on the welder. Excessive amps burn through light metals and the weld bead is flat and porous (See Figure 4). The bead appears high and irregular if the amperage is too low.

WELD ANGLE

Weld angle is the angle at which the electrode is held during the welding process. Using the correct angle ensures proper penetration and bead formation. Electrode angle involves two positions - travel angle and work angle (See Figure 5). Travel angle is the angle in the line of welding and may vary from 5° to 45° from the vertical, depending on welding conditions.

Work angle is the angle from horizontal, measured at right angles to the line of welding.

For most applications, a 45° travel angle and 45° work angle is sufficient. For specific applications, consult an arc welding handbook.

NOTE: Right handed welders should weld from left to right. Left handed welders should weld from right to left. The electrode should always point into the weld puddle as shown.

ARC LENGTH

Arc length is the distance from the work piece to the tip of the electrode, the distance which the arc must travel. A proper arc length is essential to generate the heat needed for welding (See Figure 4). An arc that is too long produces an unstable arc, reduces penetration, increases spatter, and causes flat and wide beads. Too short an arc does not create enough heat to melt the work piece, the electrode has a tendency to stick, penetration will be poor, and uneven beads with irregular ripples result. A proper arc should be no longer than the diameter of the rod. The sound of a proper arc is a steady, crisp sizzle, similar to bacon frying.

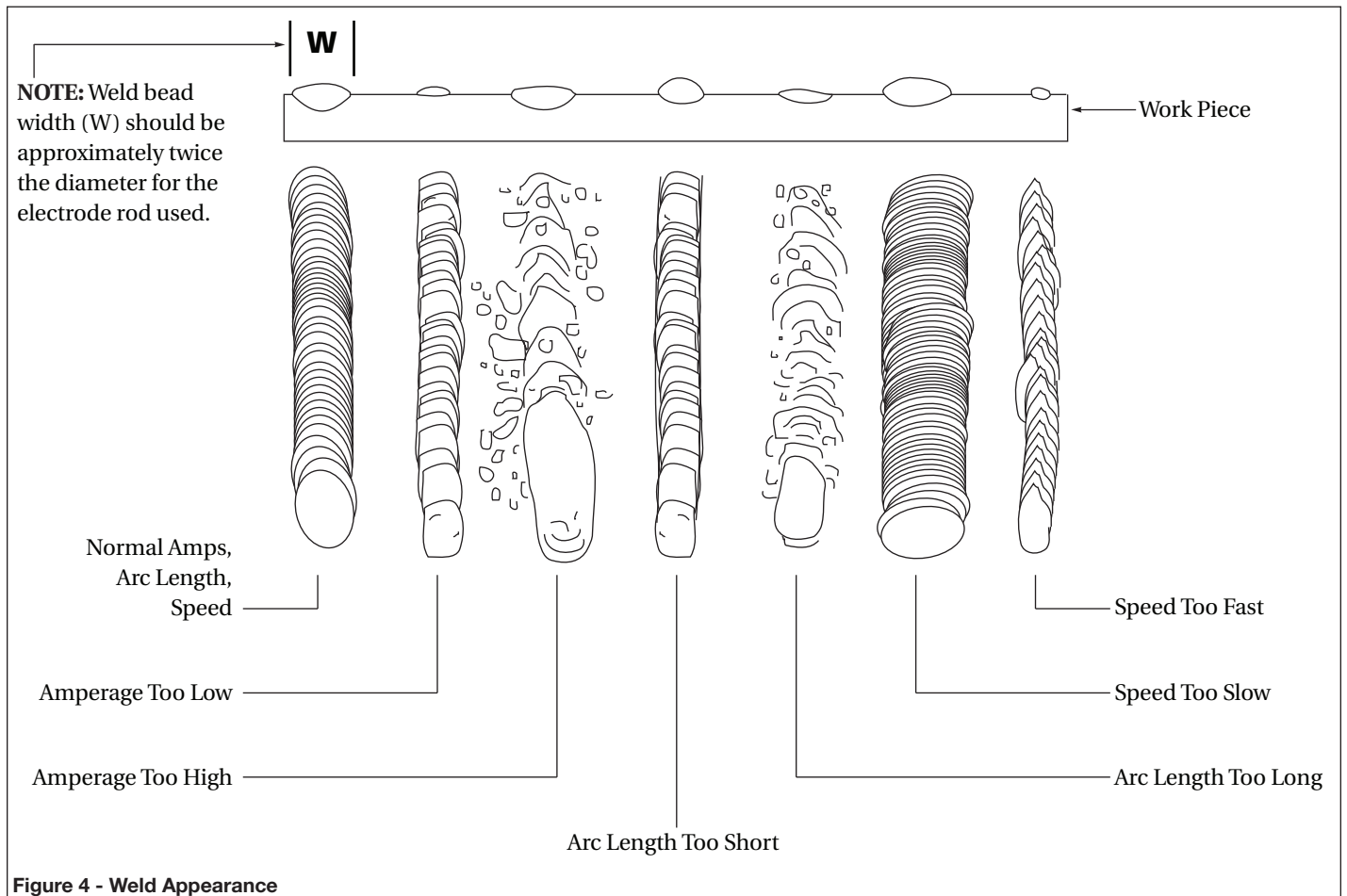

Figure 4 - Weld Appearance

Welding Guidelines (Continued)

TRAVEL SPEED

The travel speed is the rate at which the electrode is moved across the weld area (See Figure 4). When the speed is too fast, the bead is narrow and bead ripples are pointed as shown. When the speed is too slow, the weld metal piles up and the bead is high and wide. To control travel speed, watch the width of the weld bead (not the arc) when welding. The weld bead is the orange, molten metal behind the arc. The width should be approximately twice the diameter of the welding rod. Control travel speed to obtain a consistent bead width.

SLAG REMOVAL

⚠ WARNING

Wear ANSI compliant safety glasses (ANSI Standard Z87.1) and protective clothing when removing slag. Hot, flying debris can cause personal injury to anyone in the area.

After completing the weld, wait for the welded sections to cool. A protective coating called slag now covers the weld bead which prevents contaminants in the air from reacting with the molten metal. Once the weld cools to the point that it is no longer glowing red, the slag can be removed. Removal is done with a chipping hammer. Lightly tap the slag with the hammer and break it loose from the weld bead. The final clean-up is done with a wire brush. When making multiple weld passes, remove the slag before each pass.

WELDING POSITIONS

Four basic welding positions can be used; flat, horizontal, vertical, and overhead. Welding in the flat position is easier than any of the others because welding speed can be increased, the molten metal has less tendency to run, better penetration can be achieved, and the work is less fatiguing.

Other positions require different techniques such as a weaving pass, circular pass, and jogging. A higher skill level is required to complete these welds.

All work should be performed in the flat position if possible. For specific applications, consult an arc welding handbook.

WELD PASS

Sometimes more than one pass is necessary to fill the joint. The root pass is first, followed by filler passes and the cover pass (See Figures 6 and 7). If the pieces are thick, it may be necessary to bevel the edges that are joined at a 60° angle. Remember to remove the slag before each pass.

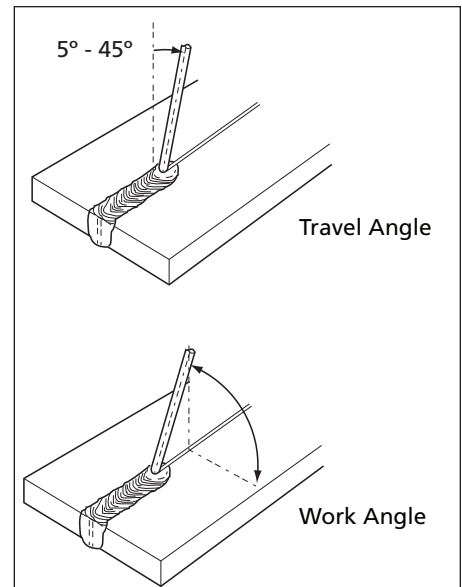

Figure 5 - Weld Angle

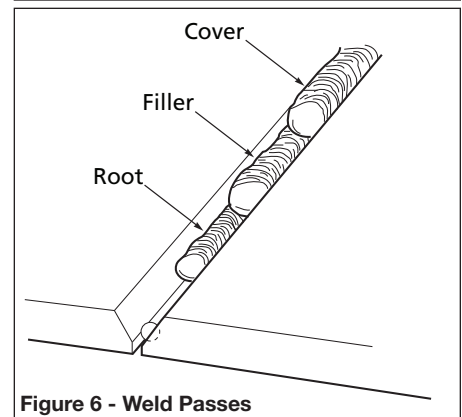

Figure 6 - Weld Passes

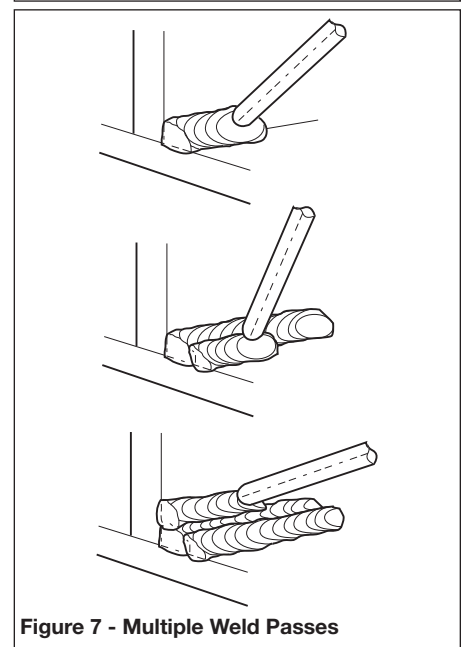

Figure 7 - Multiple Weld Passes

Welding Guidelines (Continued)

TESTING WELDER/GENERATOR DIODES

The following method eliminates the need to disconnect the diodes from the welder/generators wiring.

1. Use a 12 Volt battery and automotive lamp (Type 5001) to test the diodes in the welder/generators.
2. Connect the battery and lamp as shown in Figure 8.
3. If the diodes are operating properly, the lamp illuminates brightly when the battery polarity is correct, and goes dim when battery polarity is reversed.
4. If there is no change in lamp brightness when polarity is reversed, the diodes must be replaced.

⚠ WARNING

For testing of rotor, stator, or field windings, consult an authorized service center.

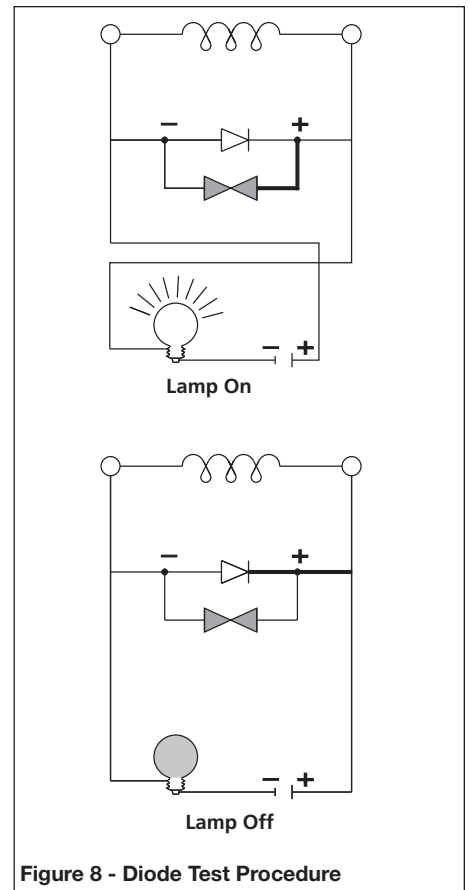

Figure 8 - Diode Test Procedure

Troubleshooting Chart

General

Symptom	Possible Cause(s)	Corrective Action
Engine will not start	<ol style="list-style-type: none"> 1. Engine switch is set to "OFF". 2. Fuel valve is turned to "CLOSE". 3. Choke is open. 4. Engine is out of gas. 5. Engine is filled with contaminated or old gas 6. Spark plug is dirty. 7. Spark plug is broken. 8. Unit is not on level surface. 9. Oil is low. 	<ol style="list-style-type: none"> 1. Set engine switch to "ON". 2. Turn fuel valve to "OPEN" position. 3. Close the choke. 4. Add gas. 5. Change the gas in the engine. 6. Clean spark plug. 7. Replace spark plug. 8. Move unit to a level surface to prevent low oil shutdown from triggering. 9. Add or replace oil.
Engine runs but there is no electrical output	<ol style="list-style-type: none"> 1. Circuit reset button is off. 2. Bad connecting of wires / cables. 3. Bad electrical device connected to unit. 	<ol style="list-style-type: none"> 1. Wait for 2 minutes and push the circuit reset button to the "ON" position. 2. If you are using an extension cord, use only heavy-duty extension cords that are specifically designed for outdoor use. Make sure the wattage rating for each cord exceeds the total wattage of all appliances connected to the unit. 3. Try connecting a different device.
Unit runs but does not support all electrical devices connected.	<ol style="list-style-type: none"> 1. Unit is overloaded 2. Short in one of the connected devices. 3. Air cleaner is dirty. 	<ol style="list-style-type: none"> 1. Turn off all electrical devices. Unplug all electrical devices. Turn off unit. Wait several minutes. Restart unit. Try connecting fewer electrical loads to the unit. 2. Try disconnecting any faulty or short-circuited electrical loads. 3. Clean or replace air cleaner.

Troubleshooting Chart (Continued)

Generator

Symptom	Possible Cause(s)	Corrective Action
No output voltage	<ol style="list-style-type: none"> 1. Engine speed is too slow 2. Open, shorted, or incorrect wiring 3. Faulty capacitor 4. Open or shorted field windings 5. Open diodes 6. Front panel switch set incorrectly 7. Circuit breaker tripped 	<ol style="list-style-type: none"> 1. Adjust engine speed ★ 2. Referring to the wiring diagram, clean and reconnect all wiring ★ 3. Replace capacitor ★ 4. Test winding resistance, replace field winding if necessary ★ 5. Test diodes, replace if necessary ★ 6. Set front panel switch to generator 7. Reset circuit breaker
Low output voltage with no load	<ol style="list-style-type: none"> 1. Engine speed is too slow 2. Open diodes 3. Faulty capacitor 4. Open or shorted field windings 5. Voltage setting on front panel incorrect 	<ol style="list-style-type: none"> 1. Adjust engine speed ★ 2. Test diodes, replace if necessary ★ 3. Replace capacitor ★ 4. Test winding resistance, replace field winding if necessary ★ 5. Adjust setting on front panel
High output voltage with no load	<ol style="list-style-type: none"> 1. Faulty capacitor 2. Engine speed is too fast 3. Voltage setting on front panel incorrect 	<ol style="list-style-type: none"> 1. Replace capacitor ★ 2. Adjust engine speed ★ 3. Adjust setting on front panel
Low output voltage under load	<ol style="list-style-type: none"> 1. Open diode 2. Engine speed too slow at full load 3. Excessive load applied 4. Voltage setting on front panel incorrect 	<ol style="list-style-type: none"> 1. Test diodes, replace if necessary ★ 2. Adjust engine speed ★ 3. Reduce the applied load 4. Adjust setting on front panel
Erratic output voltage	<ol style="list-style-type: none"> 1. Unbalanced engine 2. Dirty, corroded, or loose wiring connection 3. Unstable load applied 	<ol style="list-style-type: none"> 1. Refer to engine manual 2. Referring to the wiring diagram, clean and reconnect all wiring ★ 3. Remove all loads, then apply each one individually to determine which one is causing erratic function
Noisy operation	<ol style="list-style-type: none"> 1. Loose unit or engine bolt(s) 2. Short circuit in unit field or load 3. Faulty bearing 	<ol style="list-style-type: none"> 1. Tighten all mountings 2. Test winding resistance, replace field winding if necessary ★ Test load devices for shorts. Replace defective load device. 3. Replace bearing

★ These diagnostic and repair procedures should be performed by an authorized service center.

Welder

Symptom	Possible Cause(s)	Corrective Action
Welder runs but does not weld	<ol style="list-style-type: none"> 1. Inadequate current at electrode 2. Poor connections at welder 3. Front panel switch set incorrectly 4. Open, shorted, or incorrect wiring 5. Faulty capacitor 6. Open or shorted field windings 7. Open diodes 	<ol style="list-style-type: none"> 1. Check work clamp, cable and connection to work piece. Check electrode cable and clamp 2. Check all welder external connections 3. Set front panel switch to weld 4. Referring to the wiring diagram, clean and reconnect all wiring ★ 5. Replace capacitor ★ 6. Test winding resistance, replace field winding if necessary ★ 7. Test diodes, replace if necessary ★
Welder gives trickle shocks	<ol style="list-style-type: none"> 1. Accidental contact with work piece 2. Current leakage caused by moist clothing or work area 	<ol style="list-style-type: none"> 1. Avoid contact with work piece 2. Make sure clothing and work area are dry
Arc difficult to strike	<ol style="list-style-type: none"> 1. Wrong type of electrode. 2. Electrode diameter too large 3. Work piece not properly grounded 4. Engine speed is too slow 	<ol style="list-style-type: none"> 1. Verify that electrode is for alternating current (AC) 2. Use smaller diameter electrode 3. Verify proper grounding. (No paint, varnish or corrosion) 4. Adjust engine speed

★ These diagnostic and repair procedures should be performed by an authorized service center.

Troubleshooting Chart (Continued)

Welds

Symptom	Possible Cause(s)	Corrective Action
Bead is intermittently too thin or too thick	<ol style="list-style-type: none"> 1. Inconsistent travel speed 2. Output amp setting incorrect 	<ol style="list-style-type: none"> 1. Carefully watch and control the width of the molten weld bead 2. Adjust output amp setting or change to smaller diameter electrode
Ragged depressions at edge of weld	<ol style="list-style-type: none"> 1. Travel speed too fast 2. Arc length too short 3. Output amp setting too high 	<ol style="list-style-type: none"> 1. Watch orange molten weld puddle and control bead width 2. Practice running electrode across workpiece with welder OFF 3. Reduce output amp setting
Weld bead does not penetrate base metal	<ol style="list-style-type: none"> 1. Inconsistent travel speed 2. Output amp setting too low 3. Electrode diameter too large 	<ol style="list-style-type: none"> 1. Decrease and maintain constant travel speed 2. Increase output amp setting 3. Change to smaller diameter electrode
Electrode sticks to workpiece	<ol style="list-style-type: none"> 1. Arc length short 2. Amp setting low 3. Incorrect electrode 	<ol style="list-style-type: none"> 1. Lift electrode to correct arc length as soon as arc is struck 2. Increase amp setting or change to smaller diameter electrode 3. Verify electrode is suitable for 62.5 V open circuit voltage
Electrodes sputter and stick	Damp electrodes	Use dry electrodes and store in dry location

Notes

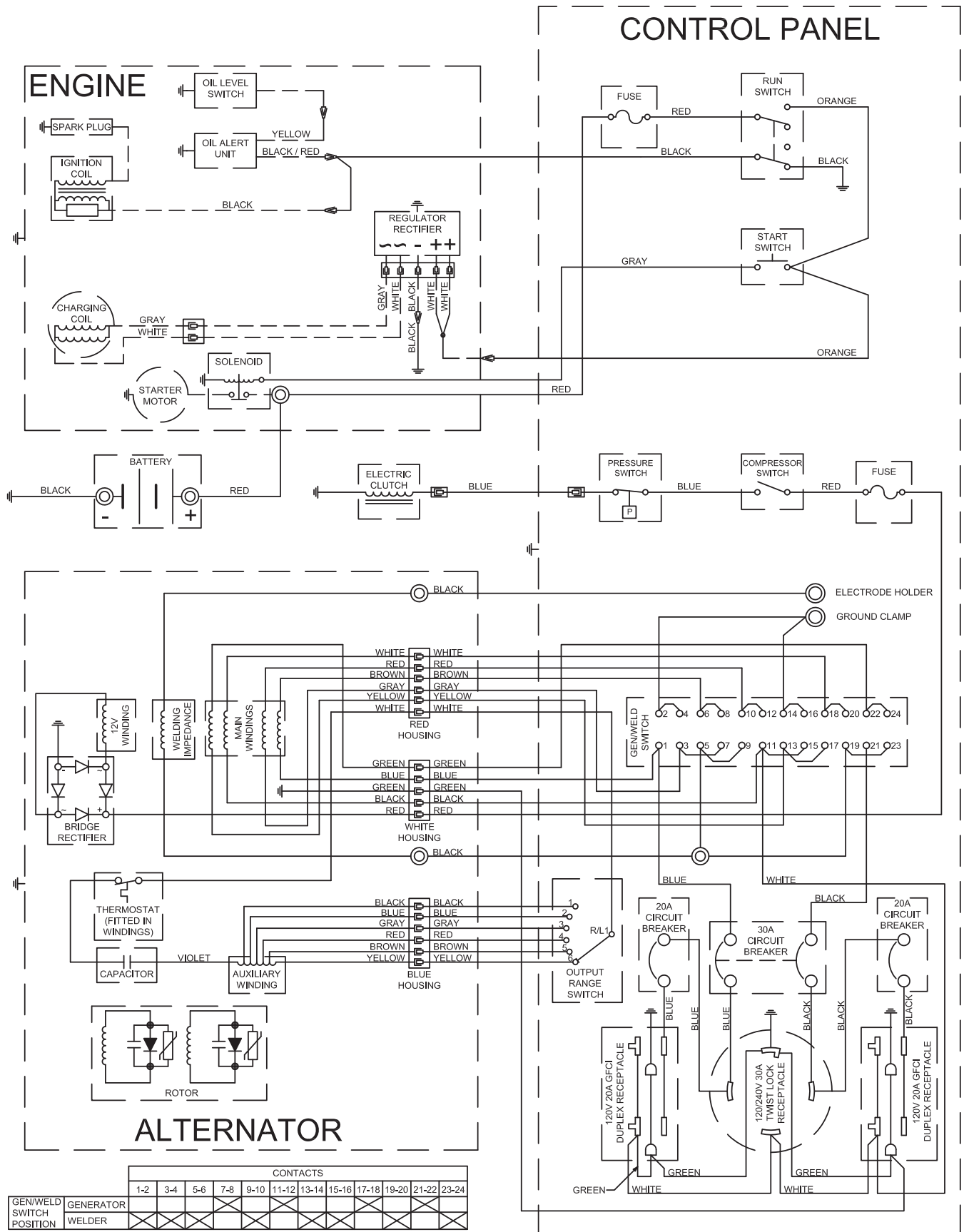

Figure 9 - Wiring Diagram

Reminder: *Keep your dated proof of purchase for warranty purposes! Attach it to this manual or file it for safekeeping.*

Limited Warranty

1. **DURATION:** The manufacturer warrants that it will repair, at no charge for parts or labor, the following Campbell Hausfeld products proven defective in material or workmanship, during the following time period(s) after date of original retail purchase:
 - For 5 Years: The Welder Transformer and Rectifier
 - For 3 Years: The Entire Welder, Engine Driven Welder Generators, and Power Packs (excluding clamps, welding gun, electrode holder, cables, or accessories packed with the welder)
 - For 1 Year: The compressor pump
 - For 90 Days: The Welding Clamps, MIG Gun, Electrode Holder, Accessories, and Welding Cables (as applicable)
 2. **WHO GIVES THIS WARRANTY (WARRANTOR):** Campbell Hausfeld/Scott Fetzer Company, 100 Mundy Memorial Drive, Mount Juliet, Tennessee, 37122, Telephone: (800) 746-5641
 3. **WHO RECEIVES THIS WARRANTY (PURCHASER):** The original purchaser (other than for purposes of resale) of the Campbell Hausfeld product.
 4. **WHAT IS COVERED UNDER THIS WARRANTY:** Substantial defects in material and workmanship which occur within the duration of the warranty period with the exceptions noted below.
 5. **WHAT IS NOT COVERED UNDER THIS WARRANTY:**
 - A. Implied warranties, including those of merchantability and FITNESS FOR A PARTICULAR PURPOSE ARE LIMITED IN DURATION TO THIS EXPRESS WARRANTY. After this period, all risks of loss, from whatever reason, shall be on the purchaser. Some States do not allow limitation on how long an implied warranty lasts, so the above limitations may not apply to you.
 - B. ANY INCIDENTAL, INDIRECT, OR CONSEQUENTIAL LOSS, DAMAGE, OR EXPENSE THAT MAY RESULT FROM ANY DEFECT, FAILURE, OR MALFUNCTION OF THE CAMPBELL HAUSFELD PRODUCT. Some States do not allow limitations on how long an implied warranty lasts, so above limitations may not apply to you.
 - C. Any failure that results from accident, purchaser's abuse, neglect or failure to operate products in accordance with instructions provided in the owner's manual(s) supplied with product.
 - D. Pre-delivery service, e.g. assembly, oil or lubricants, and adjustment.
 - E. Items or service that are normally required to maintain the product, e.g. lubricants, filters and gaskets, etc.
 - F. Gasoline engine components are expressly excluded from coverage under this limited warranty. Such components should be returned by the purchaser to the original manufacturer or to its authorized repair stations for service.
 - G. Additional items not covered under this warranty:
 1. Any component damaged in shipment or any failure caused by installing or operating unit under conditions not in accordance with installation and operation guidelines or damaged by contact with tools or surroundings.
 2. Pump or valve failure caused by rain, excessive humidity, corrosive environments or other contaminants.
 3. Cosmetic defects that do not interfere with functionality.
 4. Rusted tanks, including but not limited to rust due to improper drainage or corrosive environments.
 5. Check valves and pressure switches after the first year of ownership.
 6. Drain cocks.
 7. Other items not listed but considered general wear parts. In addition, this warranty does not extend to any damage caused by the untimely replacement or maintenance of any aforementioned wear parts.
 8. Pressure switches, air governors and safety valves modified from factory settings.
 9. Pump wear or valve damage caused by using oil not specified.
 10. Pump wear or valve damage caused by any oil contamination or by failure to follow proper oil maintenance guidelines.
 11. Belts.
 12. Ring wear or valve damage from inadequate filter maintenance.
 13. Manually adjusted load/unload and throttle control devices.
 6. **RESPONSIBILITIES OF WARRANTOR UNDER THIS WARRANTY:** Repair or replace, at Warrantor's option, products or components which have failed within the duration of the specific warranty period.
 7. **RESPONSIBILITIES OF PURCHASER UNDER THIS WARRANTY:**
 - A. Please call 800-746-5641 for warranty assistance.
 - B. Provide dated proof of purchase and maintenance records.
 - C. All products must be delivered or shipped to the nearest Campbell Hausfeld Authorized Service Center. Freight costs, if any, must be borne by the purchaser.
 - D. Use reasonable care in the operation and maintenance of the products as described in the owner's manual(s).
 8. **WHEN WARRANTOR WILL PERFORM REPAIR OR REPLACEMENT UNDER THIS WARRANTY:**

Repair or replacement will be scheduled and serviced according to the normal work flow at the servicing location, and depending on the availability of replacement parts.
- This Limited Warranty gives you specific legal rights and you may also have other rights which vary from state to state.
-